The
CALL BOOK
for MATCH RACING
for 2005 – 2008

International Sailing Federation
November 2004

First edition: January 1992
Second edition: May 1993
Third edition: November 1995
Fourth edition: April 1998
Fifth edition: March 2001
Sixth edition: November 2004

Published by ISAF (UK) Ltd., Southampton UK
© International Sailing Federation, (IOM) Ltd.
All rights reserved

Foreword

Match Racing has continued to develop as an important part of our sport. It is conducted extensively from the Club level through to the highest levels of competition, including the America's Cup.

The Call Book has been developed and refined since 1992 and is now in its Sixth Edition. The calls have been developed with the input from sailors and umpires alike due to the need for as much consistency as possible in responding to on the water protests. The aim of the Call Book is to help resolve any doubt amongst sailors and umpires about situations referred to in the Call Book.

This latest edition of the Call Book includes developmental changes and fine tuning of calls from the previous Call Book as well as incorporating changes made in the 2005-2008 Racing Rules of Sailing.

In drafting the calls care has been exercised to minimise the difference between Fleet Racing and Match Racing in terms of the Right of Way Rules of Part 2, however it is recognized that Match Racing is a separate discipline and that there are some differences from Fleet Racing.

It is important to note that this Call Book, like previous editions, is therefore only authoritative for umpired Match Racing.

The ISAF Racing Rules Committee trusts that competitors and umpires will continue to provide input to the Racing Rules Committee for further development of the Call Book.

Readers with comments and suggestions are invited to send them to the ISAF Secretariat.

David Tillett
Chairman
ISAF Racing Rules Committee
November 2004

Preface

I would like to thank those who have helped getting this updated version of the Umpires' Call Book for Match Racing ready in time for the implementation of the 2005 - 2008 Racing Rules of Sailing. This includes members of the Match & Team Racing Rules Working Party; Jim Capron, Luciano Giacomi and Jack Lloyd, and all the sailors and umpires who have commented in different ways.

There are three sections in the Call Book. The first 'General' section covers some issues that apply to many call situations. The second 'Umpire' section is limited to rules (or parts of rules) that are not amended by Appendix C, Match Racing Rules. The final section 'Match Racing' relates to situations involving the rules of Appendix C.

Any call involving contact will also involve rule 14. However, as explained in Call GEN 2, rule 14 has no impact on the immediate umpire decision and therefore is not addressed in each separate call.

This book has been revised to reflect the changes to the Racing Rules of Sailing and Appendix C. Most of the changes are simply changes to the rules references, but some of the calls have changed significantly as a result of the changes to the rules. From the 2001 - 2004 version of the Call Book UMP 31 has been deleted. (Previously UMP 8, 15, 23, 25 and MR 5, 9, 20 have been deleted.)

Although some calls are deleted, the remaining calls have not been renumbered. This means that for instance UMP 32 will now follow directly after UMP 30.

Diagrams are limited to 2-dimensional snapshots of each incident. They cannot show the wind strength, the waves, the heel and speed of boats and all the many other things that contribute to a real-life scenario. They should therefore not be used too literally, but rather as a tool to help recognise quickly and clearly the situation being addressed.

In the back of the book there is an index which enables calls to be found by key words and rule numbers.

The publishing of the Call Book is governed by ISAF regulation 31. This means that it is authoritative for umpired match racing only. It also means that changes can only be made through the same submission procedures as changes to the rules themselves.

However, ISAF regulation 31 also provides for a system with Rapid Response Match Racing Calls. Calls proposed under this system should be presented in a format similar to existing calls, and sent to the ISAF office in Southampton. Any diagrams should preferably be in TSS. (TSS is a special boat drawing program.) A call approved as a Rapid Response Call will be immediately communicated to all IU's, MNA's and to anyone who request to be on the mailing list for such calls. It will also be posted on ISAF's website www.sailing.org.

The Match & Team Racing Rules Working Party will make recommendations on submitted calls and approved Rapid Response Calls to the Racing Rules Committee November meeting each year.

I welcome any comments for improvement of the Call Book.

Marianne Orvin Middelthon, Chairman
Match & Team Racing Rules Working Party

CALL GEN 1

Question 1

There are many occasions when umpires are required to judge the exact moment when the state of a boat changes or when the relationship to another boat changes. Examples are: passing beyond head to wind, establishing an overlap, approaching the line to start, etc. How do umpires ensure that they make consistent decisions?

Answer 1

It is not possible to be entirely consistent and most judgements depend on perfect positioning which is not always practical. Umpires will assume that the state of a boat or the relationship with another has not changed until they are certain that it has changed. For example, a boat is not judged 'beyond head to wind' until the umpires are certain that she is so.

This is known as the principle of 'last point of certainty'.

Question 2

When the umpires disagree or are in doubt, what should the call be?

Answer 2

Disagreement or doubt about the facts may be resolved by Question 1/Answer 1. In many situations the 'Yellow' umpire has the responsibility to observe 'Yellow', while the 'Blue' umpire is observing 'Blue'. In these circumstances additional weight should be given to the observations of the appropriate umpire. When disagreement or doubt remains, and there has been no contact between the boats, display the green and white flag. However, if there has been contact, the umpires should penalize both boats (twin penalty).

CALL GEN 2

Rule 14 Avoiding Contact

Question

When an incident results in contact how should the umpires act with regard to rule 14?

Answer

When there has been contact there is a possibility that rule 14 has been broken. However, a breach of rule 14 will not affect any decision made by the umpires in response to a Y flag.

When the umpires decide that a boat required to keep clear or give room is to be penalized for breaking another rule of Part 2, a breach of rule 14 does not result in an additional penalty under C6.5. When a right-of-way boat or a boat entitled to room breaks rule 14 she is only liable for a penalty when damage is caused and this is subject to protest under C 6.1.

However, the umpires should initiate a check for damage to be carried out immediately after finishing. If damage is found a protest hearing should be initiated under C8.4.

CALL UMP 1

Rule 11 **On the Same Tack, Overlapped**
Rule 15 **Acquiring Right of Way**

Question

Blue establishes an overlap from clear astern. Yellow luffs immediately, and her stern hits Blue. There is a Y flag. What should the call be?

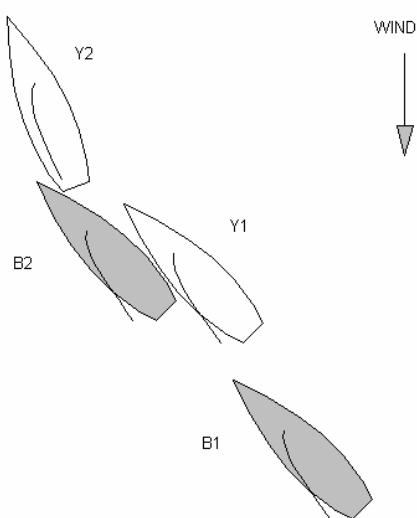

Answer

Rule 11 required Yellow to keep clear and rule 15 required Blue to initially give Yellow room to keep clear.

If Yellow luffed so that she did not take unnecessary room (see ISAF Case 24), then Blue broke rule 15. Penalize Blue.

If Yellow clearly took more room than was necessary, then Yellow broke rule 11. Penalize Yellow.

CALL UMP 2

Rule 20.3 Moving Astern

Question 1

Is a boat moving astern when she is moving astern through the water or over the ground?

Answer 1

Through the water.

Question 2

Yellow is moving astern through the water as a result of backing a sail. She releases the sail but continues to move astern through the water. Does rule 20.3 apply?

Answer 2

Yes, because moving astern was a result of backing the sail.

CALL UMP 3

Rule 11 **On the Same Tack, Overlapped**
Rule 15 **Acquiring Right of Way**

Question

Blue and Yellow are on the same tack, with Blue clear ahead. Yellow is moving faster than Blue. Blue bears away and the boats become overlapped. Blue then turns the other way and there is a collision. There is a Y flag. What should the call be?

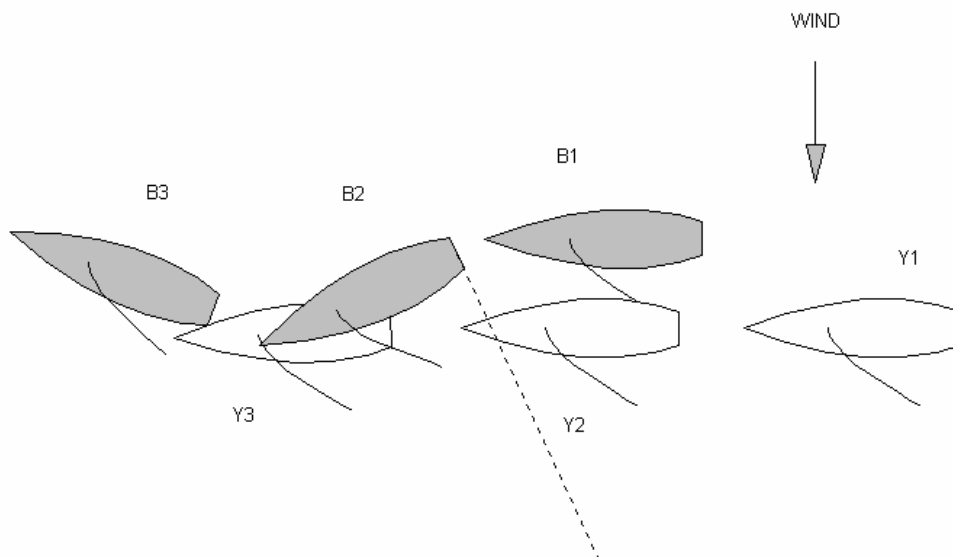

Answer

When Blue bears away, Yellow acquires right of way, at least in part, through Blue's actions. Therefore the second part of rule 15 applies, so she does not have to give Blue room to keep clear. Penalize Blue.

CALL UMP 4

Rule 11 **On the Same Tack, Overlapped**
Rule 16.1 **Changing Course**

Question

Yellow and Blue are sailing parallel courses. Yellow bears away hard and Blue is unable to keep clear. Contact occurs. There is a Y flag. What should the call be?

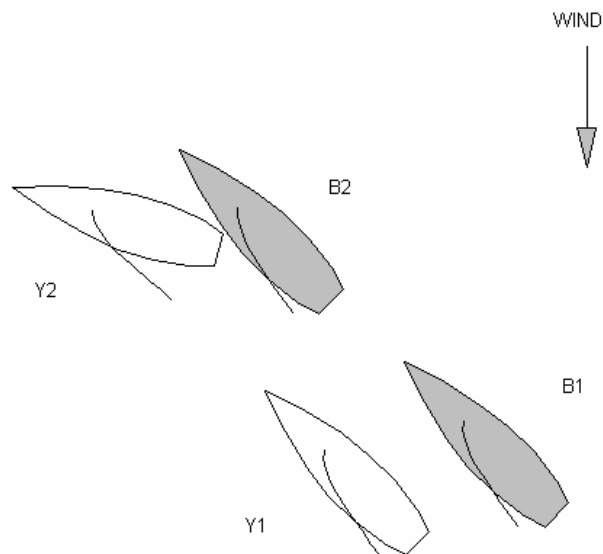

Answer

Yellow is a right-of-way boat changing course. She did not give Blue room to keep clear and therefore broke rule 16.1. Penalize Yellow.

If Yellow had borne away slightly and immediately made contact with Blue, then Blue was not keeping clear under rule 11. Penalize Blue.

CALL UMP 5

Rule 11 **On the Same Tack, Overlapped**
Rule 16.1 **Changing Course**
Rule C2.4 **While Tacking or Gybing**

Question 1

Yellow, a leeward boat, luffs head to wind, and Blue luffs in response, so that both reach positions side by side, head to wind. Blue continues to change course and passes head to wind. In so doing she makes contact with Yellow. There is a Y flag. What should the call be?

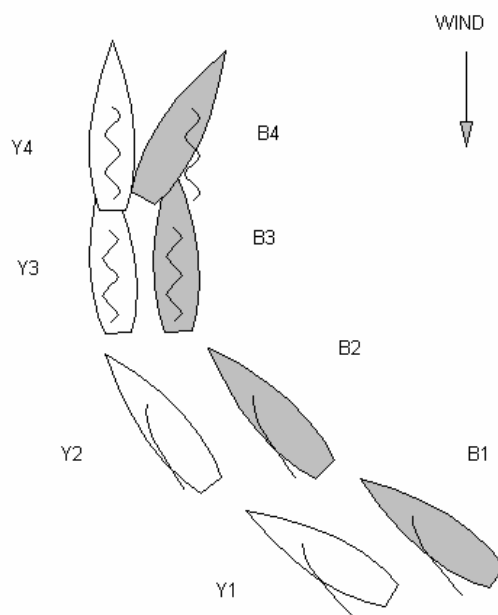

Answer 1

If, when Yellow begins her luff, Blue immediately responds and continues to do what she is able to do to keep clear throughout the incident but there is contact anyway, then Yellow is not giving Blue room to keep clear and she breaks rule 16.1. Penalize Yellow.

If Blue could have kept clear, but either responded too slowly, not enough, or over rotated, then Blue has broken rule 11 or 13.1. Penalize Blue.

Question 2

In similar circumstances, Blue responds and when head to wind, she remains so for a time. Then Yellow bears away and their sterns make contact. There is a Y flag. What should the call be?

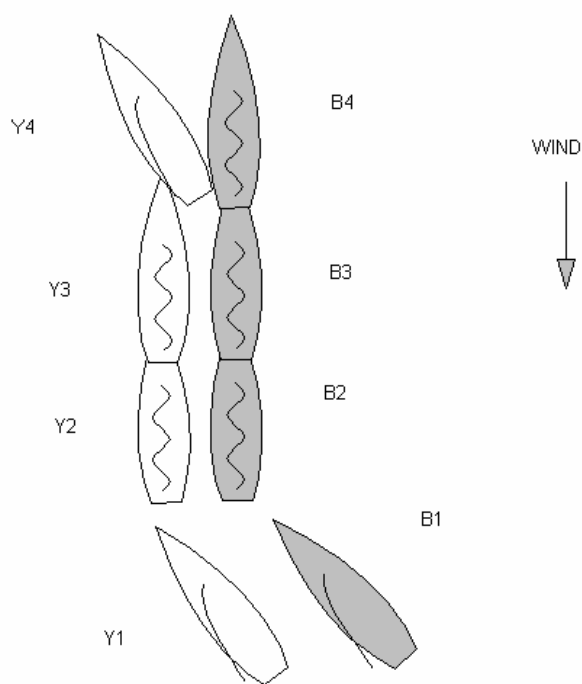

Answer 2

If Yellow's change of course immediately results in contact with Blue, Blue was not keeping clear and broke rule 11. Penalize Blue.

If there was more distance between them, and Yellow bears away hard giving Blue no room to keep clear, then Yellow breaks rule 16.1. Penalize Yellow.

The umpires' decision is based on the distance between the boats, the nature of Yellow's bear-away and the efforts of Blue to keep clear.

Question 3

In similar circumstances, Blue keeps clear, but when head to wind, she maintains it for a time. Blue then passes head to wind, and slightly later Yellow bears away and their sterns make contact. There is a Y flag. What should the call be?

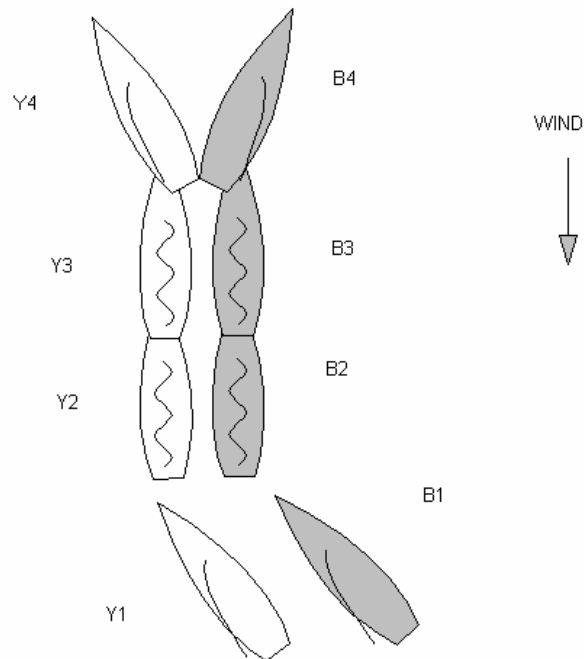

Answer 3

When Blue passes head to wind, the boats are no longer overlapped on the same tack and the second part of the definition of Keep Clear no longer applies.

If the contact would have occurred without Yellow bearing away, Blue broke rule 13.1. Penalize Blue.

If the contact would not have occurred without Yellow's bearing away, Yellow broke rule 16.1. Penalize Yellow.

CALL UMP 6

Rule 10 On Opposite Tacks
Rule 18.2(c) Rounding and Passing Marks and Obstructions: Giving room; Keeping Clear

Question 1

Before the start Yellow and Blue are reaching on starboard tack. When Yellow enters the two-length zone of an anchored spectator boat she is clear ahead of Blue. Yellow passes to windward of it, bears away alongside it, then gybes in order to sail back around its stern. Very soon after Yellow gybes, Blue is still on starboard tack and has gained a small inside overlap. Blue changes course trying to avoid contact with Yellow but there is contact and there is a Y flag. What should the call be?

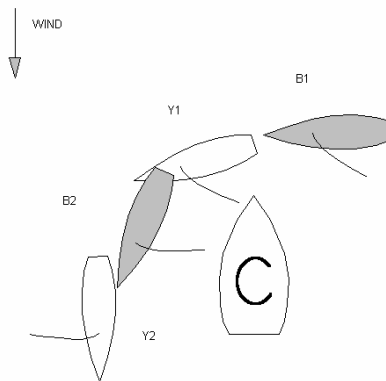

Answer 1

Rule 18.2(c) required Blue to keep clear until the boats had passed the obstruction, even if an overlap was established during the passing. Penalize Blue.

Question 2

How far beyond the obstruction may Yellow sail before gybing and still rely on rule 18.2(c)?

Answer 2

When it is clear that Blue has passed the obstruction, then rule 18 ceases to apply and Yellow may no longer rely on rule 18.2(c) to protect her when she gybes. (See also Answer 2 in CALL UMP 22.)

CALL UMP 7

Definitions Keep Clear

Question

When Blue, a keep-clear boat, passes her bow over Yellow's transom, is Blue keeping clear?

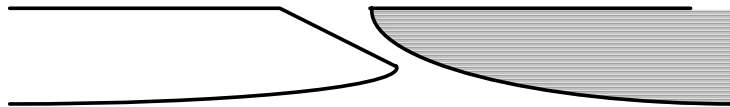

Answer

Yes.

CALL UMP 9

Rule 11	On the Same Tack, Overlapped
Rule 16.1	Changing Course
Rule 17.1	On the Same Tack; Proper Course
Definitions	Keep Clear and Proper Course

Question 1

Yellow and Blue are sailing parallel courses. Rule 17.1 does not apply. Blue has adequate room to move away but nevertheless maintains a parallel course. After about 10 seconds Yellow luffs slowly and from the moment the luff starts, there is no longer any means of Blue avoiding Yellow. Blue luffs and there is contact. There is a Y flag. What should the call be?

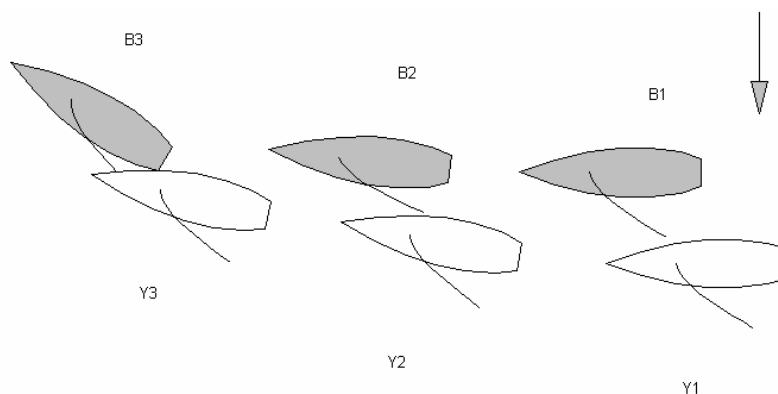

Answer 1

When Blue has had an opportunity to keep clear but then sails so close to Yellow that any luff by Yellow will result in contact, Blue fails to keep clear and breaks rule 11. Penalize Blue.

Question 2

Yellow and Blue are sailing downwind on starboard tack. Yellow establishes an overlap one and a half hull lengths to leeward of Blue. Yellow luffs slowly clearly above a proper course. Blue keeps her course and there is contact. There is a Y flag. What should the call be?

Answer 2

Penalize Blue and Yellow. Blue breaks rule 11 and Yellow breaks rule 17.1.

CALL UMP 10

Rule 18.2(a) Rounding and Passing Marks and Obstructions: Giving room; Keeping Clear

Question

Before the start, and before approaching any starting mark to start, Yellow and Blue approach a large moored boat with Yellow half a length ahead. It appears that Blue intends to pass across the stern of the large boat, and that Yellow requires room to pass on the same side on the inside of Blue. Blue does not bear away to give room, and at the last moment Yellow avoids the large boat by luffing sharply and going to windward of it. Before the bow of Blue reaches the stern of the large boat, she gybes away so that she does not pass its stern. There is a Y flag. What should the call be?

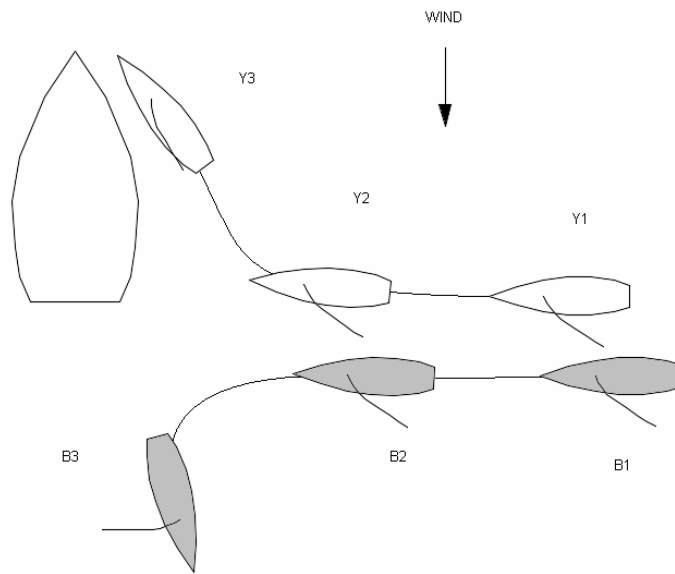

Answer

The large boat was an obstruction. Unless Blue elects to pass to windward of it from sufficiently far away, Yellow may assume that they are both going to bear away below the obstruction. It follows that Blue must give room. By not doing so, she broke rule 18.2(a). Penalize Blue.

CALL UMP 11

Rule 16.1 Changing Course Rule C2.4 While Tacking or Gybing

Question 1

Before the start Yellow and Blue are separated and not on a collision course. Blue intends to tack but after passing head to wind she loses way. Before Blue gets to a close-hauled course, Yellow bears away towards Blue. Blue is unable to take any avoiding action that would prevent a collision if Yellow were to stop bearing away. However, Yellow continues to bear away and passes astern of Blue. There is a Y flag. What should the call be?

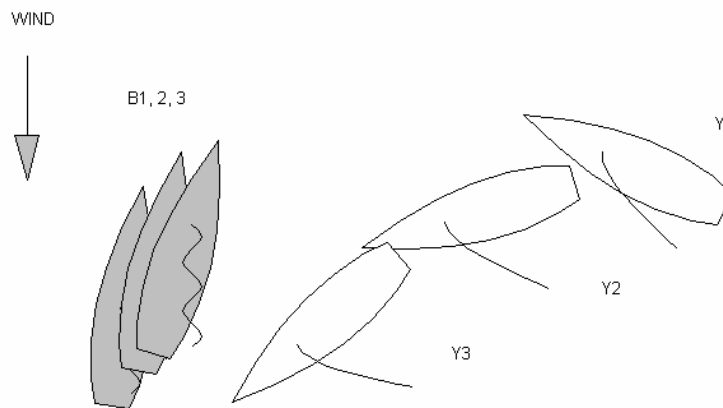

Answer 1

Yellow's change of course required her to give Blue room to keep clear (rule 16.1). Yellow complies with rule 16.1 by bearing away continuously. The same answer would apply if Blue had succeeded in completing her tack and lost way. Display the green and white flag.

Question 2

Would the answer change if Blue's helmsman had intentionally handled his boat so as to lose steerage and to place it in a situation where it would not be possible to keep clear if Yellow should change to a collision course?

Answer 2

No. No rule prohibits Blue from being in the position she was in here, whether or not she does so deliberately.

CALL UMP 12

Rules 10 **On Opposite Tacks**
Rules 16.1 **Changing Course**

Question 1

Yellow and Blue approach each other. As they pass, Blue is keeping clear to leeward. Yellow luffs and as a result Blue is unable to respond to keep clear. The stern of Yellow makes contact with the port side of Blue. There is a Y flag. What should the call be?

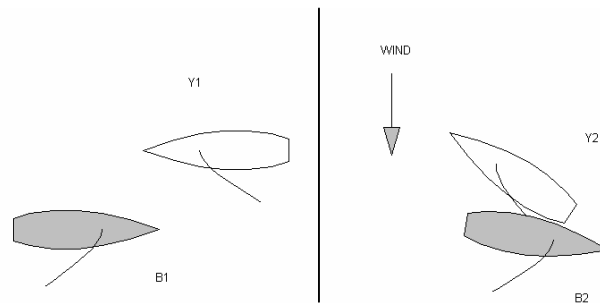

Answer 1

Yellow breaks rule 16.1 by changing course. Penalize Yellow.

Question 2

Yellow and Blue approach each other. As they pass, Blue is keeping clear to windward. Yellow bears away. Blue is unable to respond and there is contact. There is a Y flag. What should the call be?

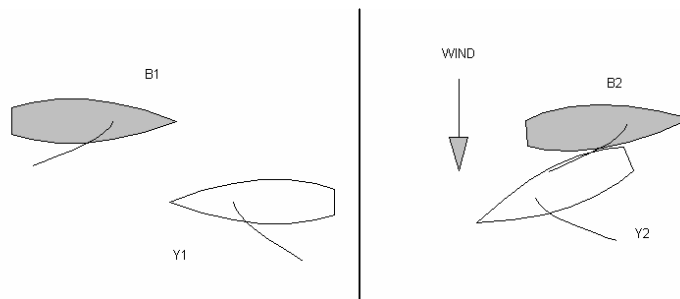

Answer 2

Yellow breaks rule 16.1 by changing course. Penalize Yellow.

CALL UMP 13

Rule 11 On the Same Tack, Overlapped Rule 18.1(a) Rounding and Passing Marks and Obstructions: When This Rule Applies

Question 1

Blue and Yellow are approaching the committee boat end of the starting line. How do the umpires decide if they are approaching a starting mark to start?

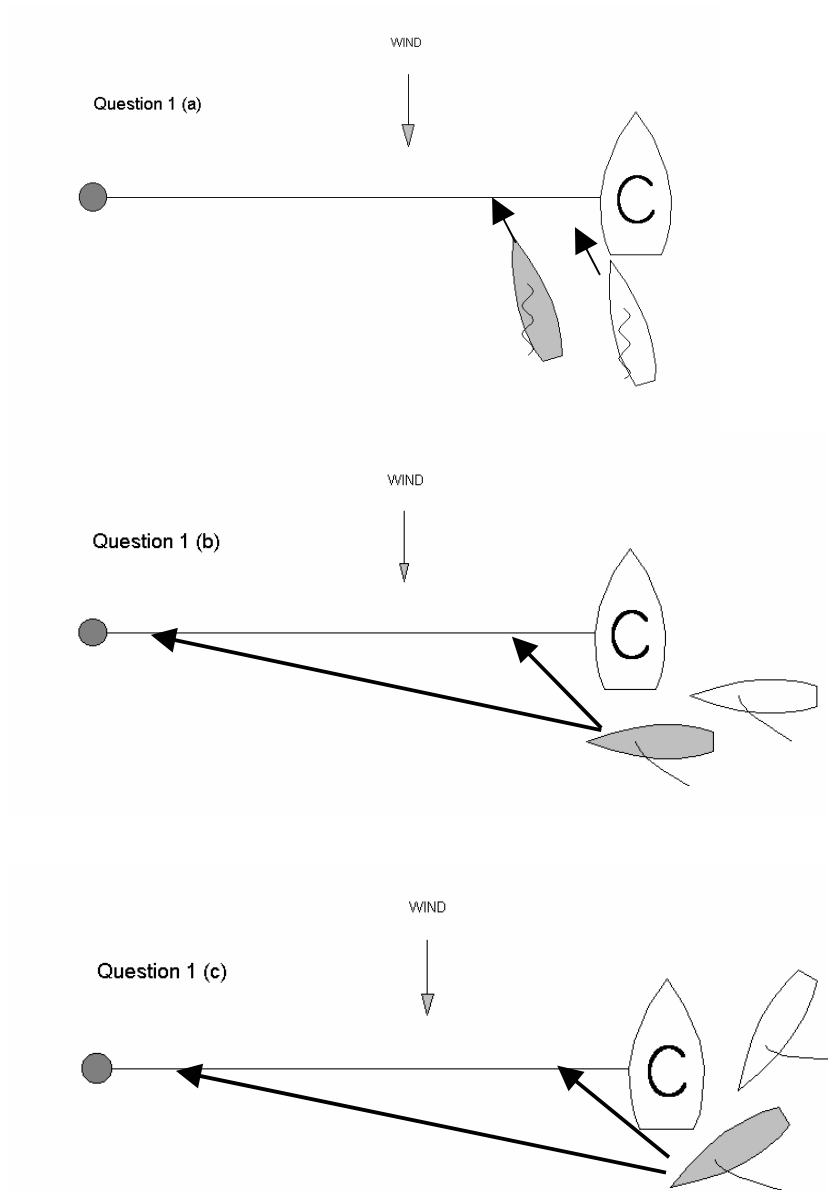

Answer 1

In each of Diagrams a, b, and c the boats may be approaching a starting mark to start. The umpires will use the speed and course of the boats in the prevailing conditions and the time remaining before the starting signal to decide if they are approaching a starting mark to start. Since match race starting lines are short, the boats may even be approaching the far end (Diagram b). However, until both umpires agree that the boats are approaching to start, they will decide that they are not (see Call GEN 1).

Question 2

Before starting Blue and Yellow are on the course side of the starting line sailing downwind on port tack. Blue gives room for Yellow to pass the committee boat. There is a Y flag. What should the call be?

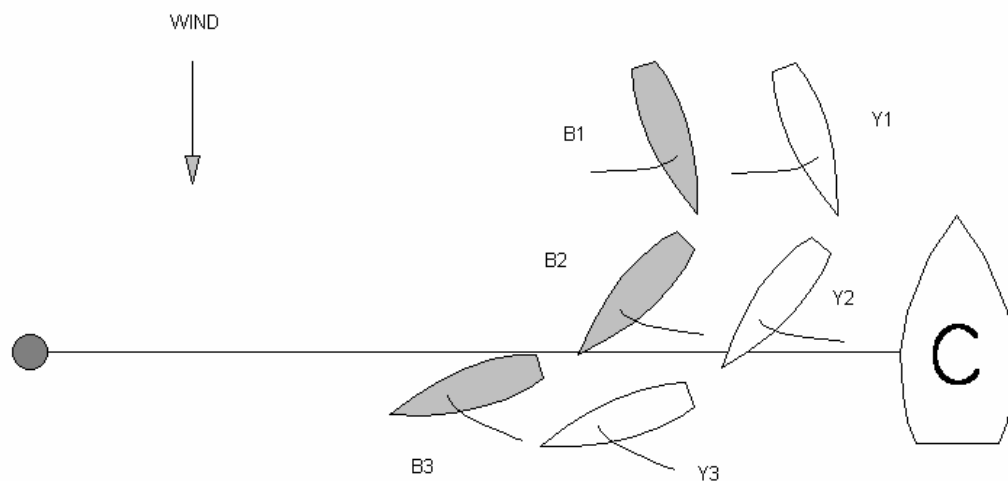

Answer 2

A boat cannot be approaching a mark to start until approaching to pass the mark on the required side. At position 1, Yellow was entitled to room, which was given. This also applies when both boats have been recalled. Display the green and white flag.

CALL UMP 14

Rule 10 **On Opposite Tacks**
Rule 16.1 **Changing Course**

Question 1

On a windward leg, Blue and Yellow approach one another. At approximately four hull lengths from Blue, Yellow bears away to avoid Blue. Blue then bears away, so that the boats remain on a collision course. Yellow and Blue continue to bear away in the same way, until they finally pass one another with the wind approximately abeam. At no time does Blue sail a downwind course. There is a Y flag. What should the call be?

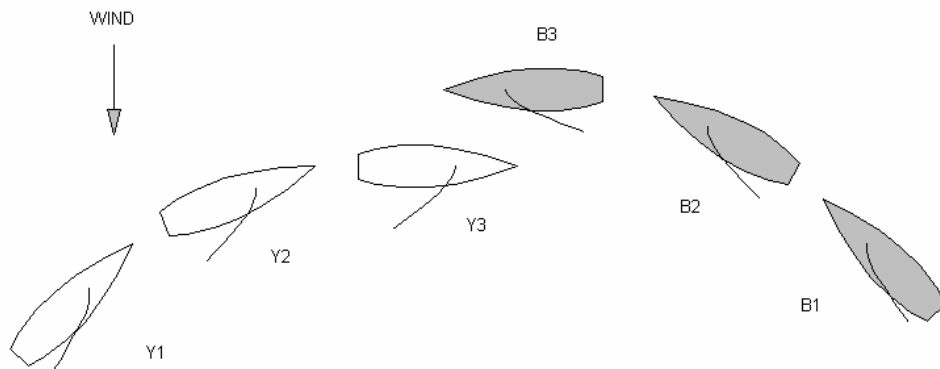

Answer 1

The relevant rule is 16.1, but Blue has not broken it, because throughout the incident she has given Yellow room to keep clear. Display the green and white flag.

Question 2

In similar circumstances, Yellow's course would allow her to cross ahead of Blue, but Blue luffs to a collision course and Yellow tacks away in a seamanlike way. There is a Y flag. What should the call be?

Answer 2

As in Question 1, the relevant rule is 16.1, and although Blue has forced Yellow to change course, she has not done so without giving her room to keep clear. Display the green and white flag.

CALL UMP 16

Rule 10 **On Opposite Tacks**
Rule 16.1 **Changing Course**

Question

Blue and Yellow approach one another on a windward leg. As Yellow bears away to pass Blue's stern, Blue luffs. Yellow attempts to bear away more but there is contact between the port quarter of Blue and the bow of Yellow. There is a Y flag. What should the call be?

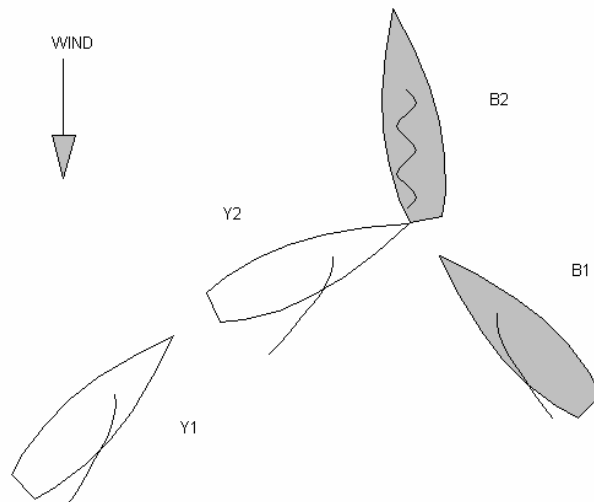

Answer

Provided the umpires are satisfied that Yellow was keeping clear before Blue luffed, Blue broke rule 16.1 by changing course without giving Yellow room. Penalize Blue.

CALL UMP 17

Rule 11 **On the Same Tack, Overlapped**
Rule 16.1 **Changing Course**
Rule 17.1 **On the Same Tack; Proper Course**

Question 1

Yellow and Blue, close-hauled on port tack, approach the layline near the windward mark. Yellow established her overlap from clear astern. Both sail beyond the layline and are clearly over standing the mark. Yellow luffs, and is then forced to bear away to avoid contact. There is a Y flag. What should the call be?

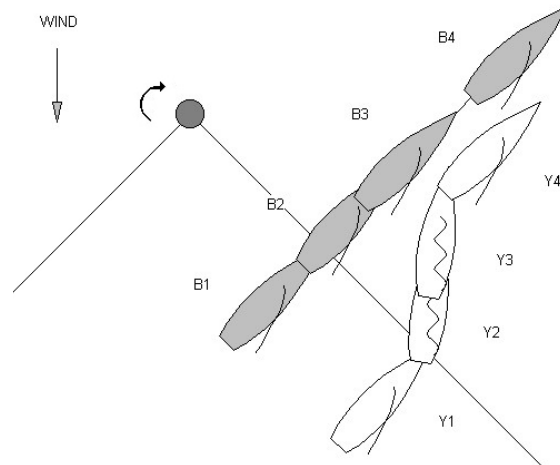

Answer 1

When Yellow luffs it is clear that her only proper course is to luff in order to tack toward the mark. Yellow gives Blue room as required by rule 16.1. Yellow is then unable to sail her course without the need to take avoiding action. Blue does not keep clear and breaks rule 11. Penalize Blue.

Question 2

What would the call be if due to shifty winds and/or rough seas it is not clear whether the boats are over standing the mark?

Answer 2

It is not yet clear that her only proper course is on the other tack. Yellow breaks rule 17.1 by sailing above her proper course (close-hauled). Penalize Yellow, unless as a result she promptly sails astern of Blue.

CALL UMP 18

Rule C2.1 Changes to the Definitions - definition Finish Definitions Clear Astern and Clear Ahead; Overlap

Question

At a close downwind finish, Yellow eases her spinnaker halyard, sheet and guy so that the sail is further ahead of her bow than normally. When does she finish? What action should the umpires take?

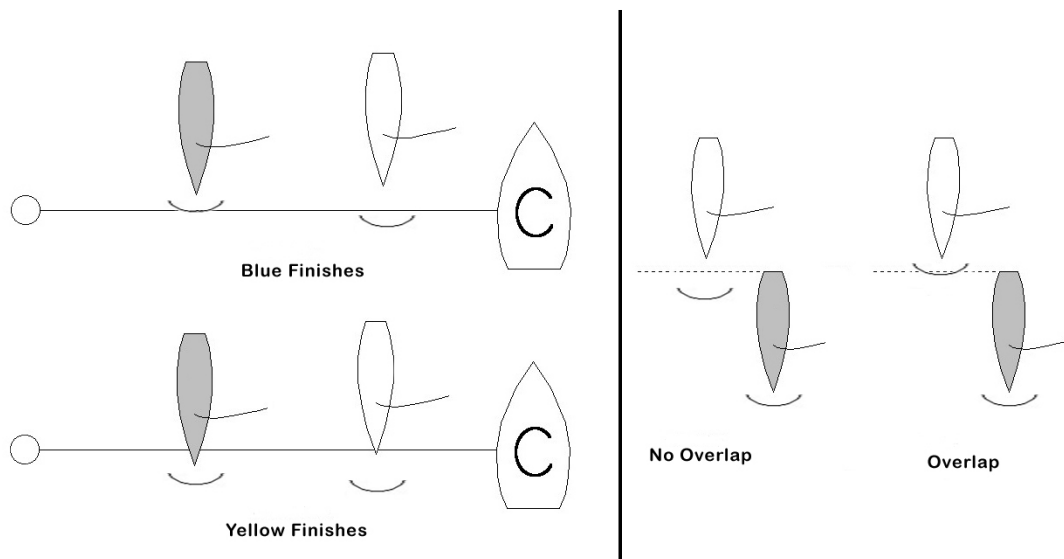

Answer

Yellow finishes when her bow crosses the line. The definition Finish makes it clear that as the spinnaker is not in normal position it cannot be considered for the purpose of finishing.

Judging the finish is solely a matter for the race committee. However, if the umpires see the halyard eased they may advise the race committee, since the umpires may be in a better position to see the spinnaker before the boat crosses the finishing line.

The same reasoning would apply when two boats approach a leeward mark and there is a question about whether they are overlapped.

CALL UMP 19

Rule 17.1 On the Same Tack; Proper Course Definitions Proper Course

Question

Nearing the end of the downwind leg, the boats are overlapped on starboard tack. Yellow has established an overlap to leeward from clear astern, is governed by rule 17.1 and is sailing her proper course. Soon her proper course will be to gybe for the mark. When must Yellow begin to bear away to gybe?

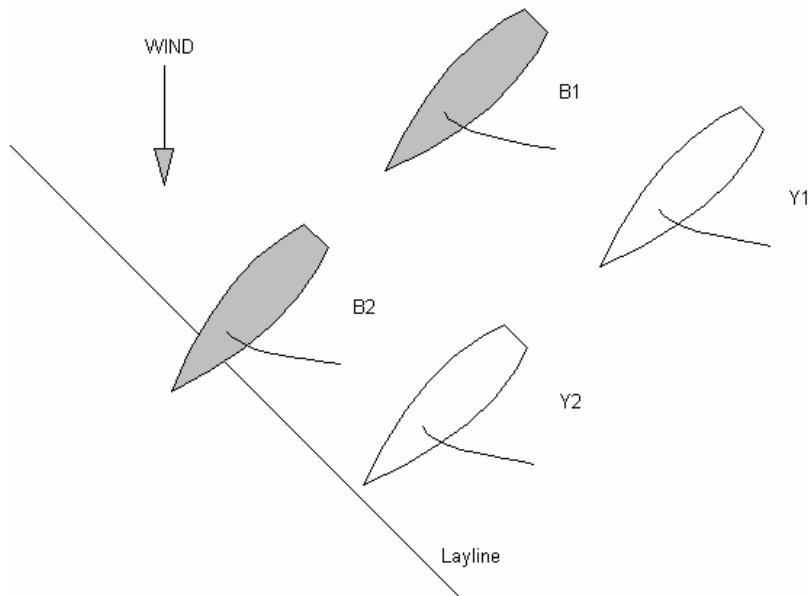

Answer

Yellow must begin to gybe at the time she would have borne away to gybe if she had been sailing with no other boat nearby. If she clearly delays beyond that time, she will break rule 17.1 by sailing above her proper course.

CALL UMP 20

Rule 16.1 **Changing Course** **Definitions** **Room**

Question 1

In the definition of Room, how should the umpires apply the phrase ‘in a seamanlike way’?

Answer 1

The question is addressed in ISAF Case 21, which refers to ‘extraordinary’ and ‘abnormal’ manoeuvres as being ‘unseamanlike’.

However, actions that are not seamanlike in a fleet of many boats may be considered seamanlike in a situation with only two boats. Thus, in match racing some manoeuvres might be considered normal that would be considered abnormal in other racing, and therefore ‘seamanlike way’ should be interpreted somewhat more broadly in match racing.

Any manoeuvre, however, that puts a boat or her crew at unreasonable risk of damage is unseamanlike. The umpires will have to judge each incident on the basis of the boat's actions in relation to the conditions of wind and water that she is experiencing.

Question 2

Blue on port tack and Yellow on starboard tack are on a leg to the windward mark. Yellow bears away to a downwind course and as a result Blue has to change course to keep clear. There is a Y flag. What should the call be?

Answer 2

Yellow breaks rule 16.1 by not giving Blue room, namely the space to manoeuvre in a seamanlike way. Penalize Yellow.

CALL UMP 21

Definitions Overlap
Definitions Keep Clear

Questions

Is a spinnaker pole in 'normal position' when the spinnaker is not set but

- (i) one end is attached to the mast and the other end is projecting beyond the bow, or
 - (ii) in the case of an extendable bowsprit-type pole, it is not retracted as fully as it can be
- (a) when the spinnaker is, or is being, set up approaching or passing a mark?
 - (b) when hoisting or lowering the spinnaker?
 - (c) when beating to windward?
 - (d) during pre-start manoeuvres?

Answers

The general test when addressing these questions is 'Is this how the boat would normally be sailed, in the absence of other boats?' This leads to the following more specific answers:

- (a) and (b), for both (i) and (ii):

Yes, if it is the regular practice for the pole to be in that position in the circumstances and the umpires are not of the opinion that the pole had been set up prematurely, or left in position too long, for the purpose of obtaining a tactical advantage (such as the establishment of an artificial overlap).

- (c) and (d), for (i);

Yes, if it is the regular practice for that boat to carry her spinnaker pole in that position. It would not be regular practice if, for example, a boat had her spinnaker pole projecting during pre-start manoeuvres but then removed it for starting, or started without the pole projecting then later changed its position so that it was then projecting.

- (c) and (d), for (ii): No.

CALL UMP 22

Rule 18.1 Rounding and Passing Marks and Obstructions: When This Rule Applies

Rule 18.2(c) Rounding and Passing Marks and Obstructions: Giving Room; Keeping Clear

Question 1

Blue and Yellow approach the windward mark on port tack with Blue clear ahead at the zone. The mark is to be rounded to starboard. Blue immediately gybes onto starboard tack. There is a Y flag. What should the call be?

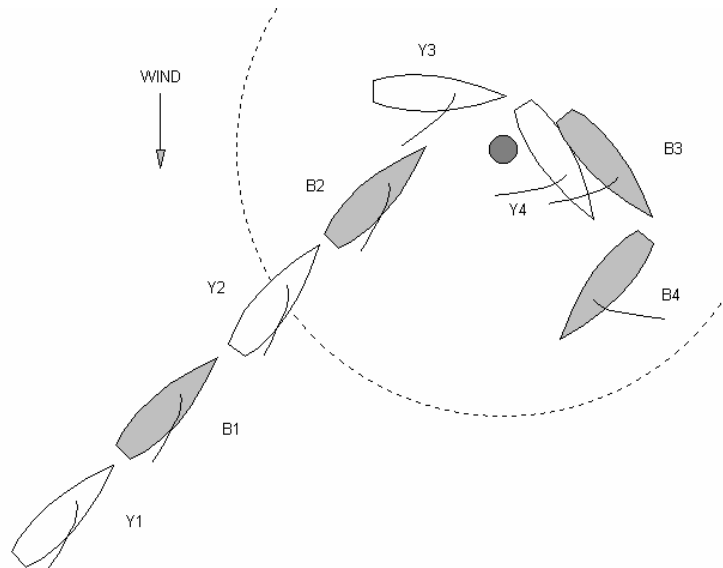

Answer 1

Rule 18.2(c) requires Yellow to keep clear. Under rule 18.1, this requirement continues to apply 'until they have passed' the mark. Display the green and white flag.

Question 2

How far beyond the mark may Blue sail before gybing and remain protected?

Answer 2

As long as Yellow is still passing the mark, 18.2(c) continues to apply and Blue remains protected. The use of 'boats' and 'they' (plural) in rule 18.1 means that rule 18 continues to apply until both boats have passed the mark.

CALL UMP 24

Rule 11 **On the Same Tack, Overlapped**
Rule 18.2 **Rounding and Passing Marks And Obstructions: Giving Room; Keeping Clear**

Question 1

Blue and Yellow are approaching a mark to be left to starboard. Rule 17.1 does not apply to Blue. What is the latest time Blue may luff?

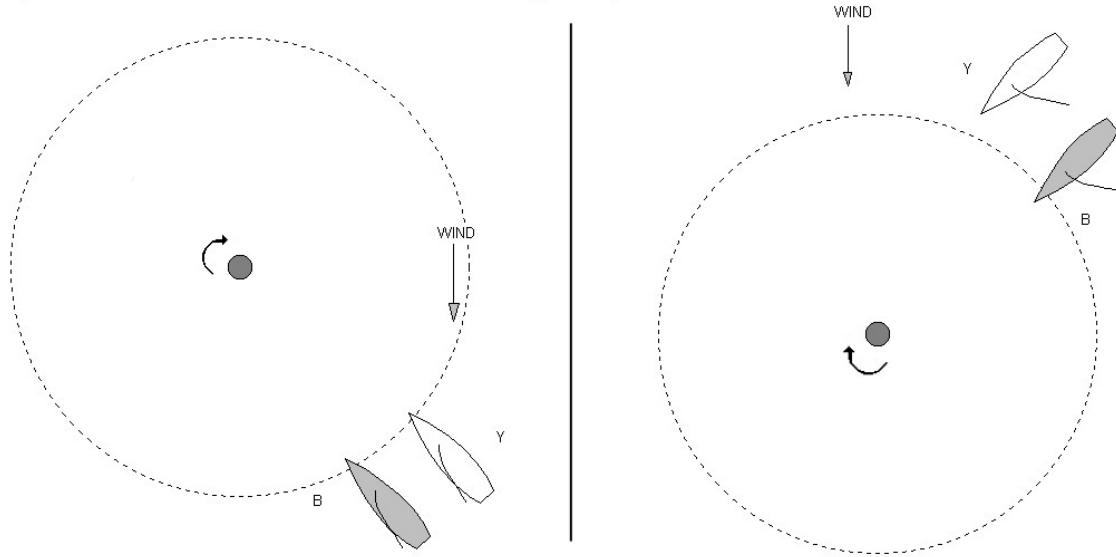

Answer 1

From the moment that the boats are about to pass the mark rule 18 begins to apply. From this moment, if Blue luffs and thereafter bears away in order to give Yellow room, or to pass the mark, then Blue breaks rule 18. If Blue is able to luff without the need to bear away later then Yellow is required to keep clear, rule 11 applies.

Question 2

If Blue will have to bear away to give room, when is she required to do so?

Answer 2

Blue is required to bear away promptly from the moment that the boats are about to pass the mark.

CALL UMP 26

Rule 49.1 Crew Positioning

Question 1

One crew member on Yellow holds on to the leeward jibsheet and another one holds on to the main sail sheet when hiking out. Does Yellow break rule 49.1?

Answer 1

No. A working sheet is not a device designed to position the body outboard.

Question 2

Does Yellow (a boat without lifelines) break rule 49.1 when the crew use any of the following to help extend their bodies outboard?

The windward, non working, jib sheet; the barber hauler; the vang control line; the mainsheet traveller line; the backstay control line; the shrouds or other elements of standing rigging

Answer 2

Rule 49.1 does not prohibit competitors from using working sheets or control lines to position their bodies outboard.

Unless specifically prohibited by the event's sailing instructions (Rules for handling the boats) it is also permissible for competitors to use the shrouds or hand rails to position their bodies outboard.

The use of lazy (non-working) sheets and control lines for hiking breaks rule 49.1.

Question 3

The skipper on Yellow holds a foot under the traveller bridge. Does Yellow break rule 49?

Answer 3

No. A traveller bridge is not a device designed to position the body outboard. Using the traveller bridge (or other fixed features of the boat) without modifications that aid projecting the body outboard is permitted.

CALL UMP 27

Rule 16.1 **Changing Course**
Rule 18 **Rounding and Passing Marks and Obstructions**
Definitions **Mark and Obstruction**

Question

The situation occurs in the pre-start, with approx. 2 minutes to the starting signal. The committee boat is also a starting mark.

Between situations 3 and 4 Blue makes a big and rapid change of course, backing her jib to bear away and does not give Yellow room to keep clear. There is contact between Blue and Yellow. Both boats Y-flag. What should the call be?

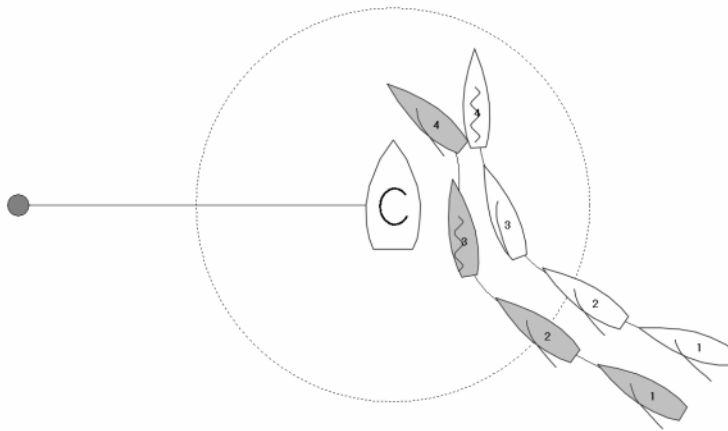

Answer

Penalize Blue. Rule 18.2(d) only applies after the starting signal and never at obstructions, so when Blue changes course she must comply with rule 16.1. Blue is a right way boat changing course. She did not give Yellow room to keep clear and broke rule 16.1.

CALL UMP 28

Rule 15 **Acquiring Right of Way**
Rule 17.1 **On the Same Tack; Proper Course**

Question

On a downwind course Yellow establishes an overlap to windward of Blue with her spinnaker. Yellow bears away, without breaking the overlap, and overlaps to leeward.

Do rules 15 and 17.1 apply?

Answer

Yes. At the moment Yellow becomes right of way as the leeward boat, rules 15 and 17.1 begin to apply.

CALL UMP 29

Rule 11 **On the Same tack**
Rule 16.1 **Changing Course**
Definitions **Keep Clear and Room**

Question 1

Shortly after the start Yellow and Blue are beating on port tack. The boats are overlapped and Yellow is keeping clear to windward. Rule 17.1 does not apply. As the boats pass to leeward of mark L, an inflatable buoy that is not a mark on this leg, Blue luffs and Yellow responds. Yellow stops luffing when she hits the mark amidships, which causes Blue to curtail her luff. Both boats display flag Y. What should the call be?

Answer 1

When Blue, the right of way boat, changes course she has to give room according to rule 16.1. It is not seamanlike to hit a mark. Penalize Blue.

Because mark L is not a mark on this leg, rules 18 and 31.1. do not apply.

Question 2

Would the answer be the same if the boats were passing to leeward of an object that was not big enough to rank as an obstruction, but nevertheless limited her ability to respond and/or could cause damage to the hull or foils?

Answer 2

Yes. Provided Yellow was initially keeping clear, Blue must give her room to respond in a seamanlike way when she changes course.

CALL UMP 30

Rule 15 **Acquiring Right of Way**
Rule 17.1 **On the Same Tack; Proper Course**
Rule 18.2 **Rounding and Passing Marks and Obstructions: Giving Room; Keeping Clear**

Question 1

Yellow enters the zone clear ahead of Blue. Both boats tack and continue to round the mark. Blue becomes overlapped inside Yellow. Both boats Y-flag, what should the call be?

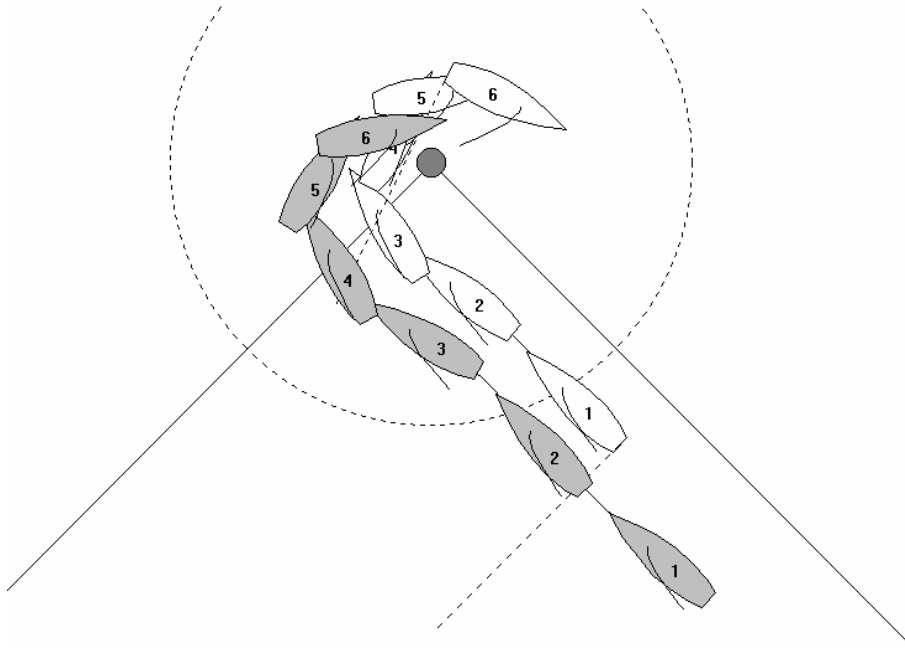

Answer 1

When Yellow enters the zone, rule 18.2(c) applies until Yellow passes head to wind. From the moment Blue becomes overlapped inside Yellow, rule 18.2(a) applies.

If the overlap is created by Blue bearing away, then rule 15 applies and Blue must initially give Yellow room to keep clear. If Yellow is unable to keep clear, penalize Blue.

However, if the overlap is created by Yellow bearing away, Blue acquires right of way, at least in part, through Yellow's actions. Therefore the second part of rule 15 applies, so Blue does not have to give Yellow room to keep clear.

Because the overlap is established from clear astern, rule 17.1 applies.

Question 2

Yellow and Blue overlapped enter the zone. Both boats tack and continue to round the mark. Blue becomes overlapped inside Yellow. Yellow's boom touches Blue's hull. Both boats Y-flag, what should the call be?

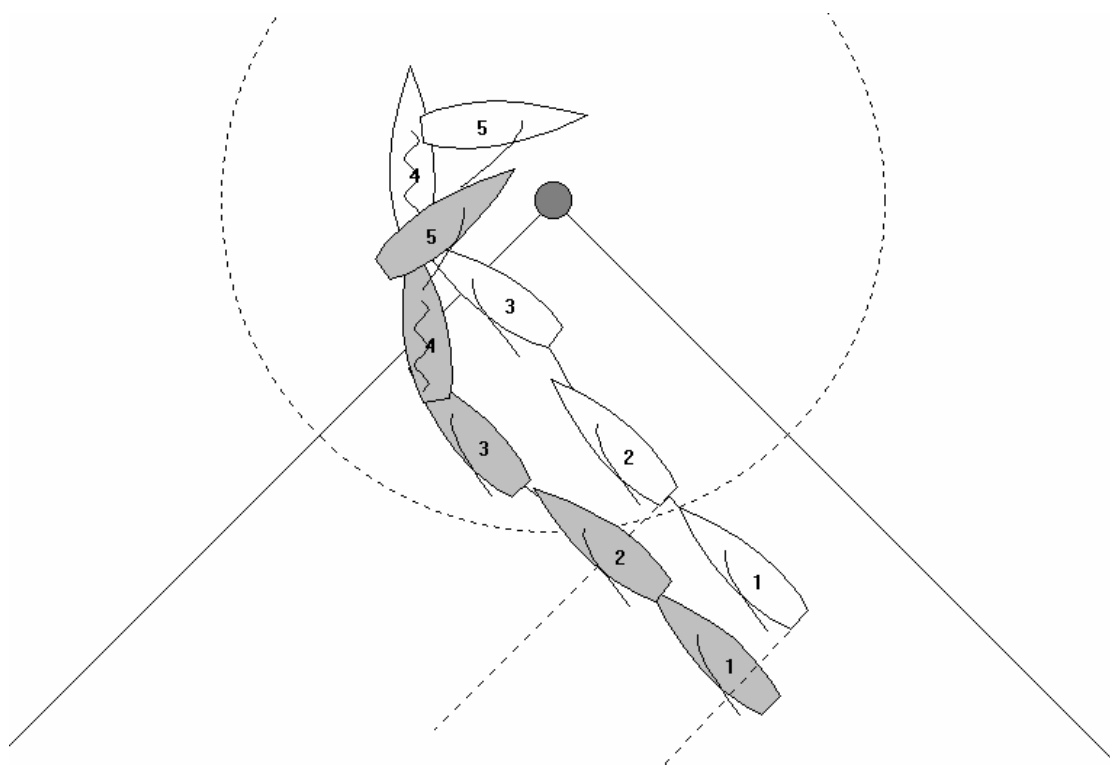

Answer 2

The boats are overlapped when they enter the zone. Rule 18.2(a) and (b) apply. Blue must give room and even if the overlap is broken (at position 4) she must continue to give room. After one of the boats passes head to wind rule 13 applies and rule 18 does not until the boats again are on the same tack. If Blue then chooses to go inside (position 5) she is NOT entitled to room and shall keep clear (18.2(b)). Penalize Blue.

CALL UMP 32

- Rule 11** **On the Same Tack, Overlapped**
Rule 16.1 **Changing Course**
Rule 18 **Rounding and Passing Marks and Obstructions: Preamble**
Rule 18.2(a) **Rounding and Passing Marks and Obstructions: Giving Room; Keeping Clear**

Question

Blue and Yellow approach the windward mark overlapped on port tack with Yellow to leeward and on the layline at the zone. Rule 17.1 does not apply to Yellow. Before Yellow passes the mark she luffs Blue head to wind. Blue responds to the luff and keeps clear. There is a Y flag. What should the call be?

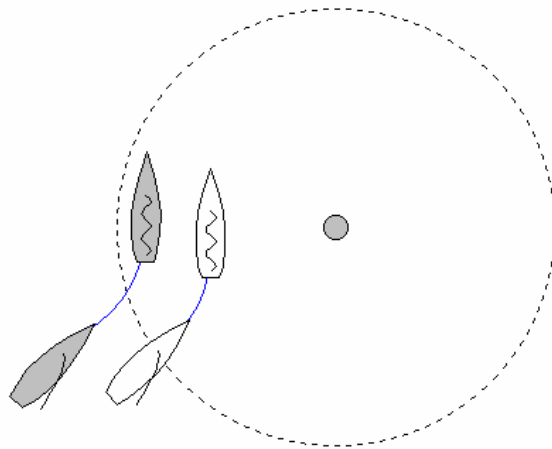

Answer

Blue is required by rule 11 and rule 18 to keep clear and give room - and she does so. Because Yellow's luff is inconsistent with rounding or passing the mark, rule 16.1 requires her to give Blue room to keep clear. However, rule 17.1 does not apply, and nothing in the rules prevents Yellow from sailing above her proper course while the boats are passing the mark.

Display the green and white flag.

CALL UMP 33

Rule 16.1 **Changing Course** **Definitions** **Room**

Question 1

Blue is sailing to leeward of Yellow. Rule 17.1 does not apply. Both boats have spinnakers set. Blue luffs Yellow. What are the obligations on Blue and Yellow?

Answer 1

Yellow is required to keep clear and Blue is required to give Yellow room to respond to her luff. While Yellow is able to keep the majority of her spinnaker filled and drawing she is not entitled to additional room to drop her spinnaker.

If Blue continues her luff so that Yellow, in order to keep clear, has to luff beyond the point where she can keep her spinnaker filled and drawing, then Blue must give Yellow room to drop her spinnaker.

Whether or not Yellow drops her spinnaker at that time, she is still required to keep clear. If she does not drop her spinnaker at that time, then Blue is not required to give her additional room to drop the spinnaker later in that luff.

Question 2

If Yellow does not drop her spinnaker and passes head to wind to keep clear, is Blue giving Yellow room to keep clear in a seamanlike way?

Answer 2

Yes. Blue may continue to luff as long as she has previously given Yellow room to drop her spinnaker.

Question 3

Does either answer change if Blue does not have a spinnaker set, or if Blue has a different type of spinnaker set?

Answer 3

No.

CALL UMP 34

Rule 18.2(a) Rounding and Passing Marks and Obstructions: Giving Room; Keeping Clear: Overlapped – Basic Rule

Rule 18.2(e) Rounding and Passing Marks and Obstructions: Giving Room; Keeping Clear: Overlap Rights

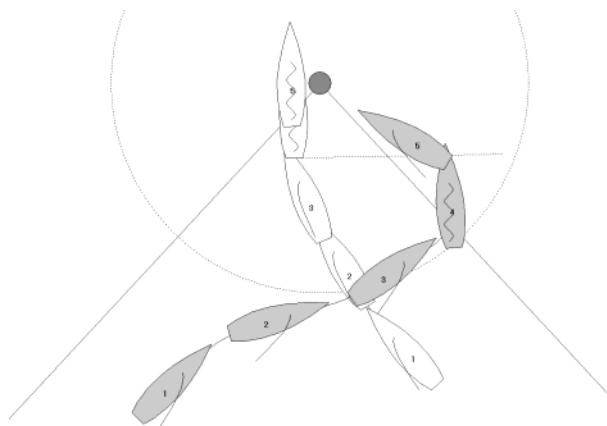

Question 1

Yellow on starboard tack and Blue on port tack, both close-hauled, are approaching the windward mark. Blue bears away and passes astern of Yellow. Yellow luffs slowly and nearly stops head to wind with the mark abeam. While Yellow is luffing Blue tacks to starboard and bears away towards the mark. Yellow does not give room at the mark, and Blue luffs to avoid a collision. There is a Y-flag from Blue. What should the call be?

Answer 1

The boats enter the two-length zone on opposite tacks on a beat to windward. Therefore, rule 18 does not apply. When Blue has passed head-to-wind, the boats are overlapped on the same tack and are both about to round the mark. Therefore, rule 18 applies. There was neither an overlap nor were they clear ahead/clear astern when the first of the two boats entered the two-length zone. Rule 18.2(a) applies and this requires Yellow to give Blue as an inside boat room to round the mark.

If Yellow is unable to give room in time for Blue to round inside her, rule 18.2(e) applies. Display the green and white flag.

If Yellow is able to give room in time for Blue to round inside her, rule 18.2(a) applies. Yellow fails to give this room. Penalize Yellow.

Question 2

Will the answer be different if Blue completes her tack outside the two-length zone?

Answer 2

No.

CALL UMP 35

Rule 10 On Opposite Tacks Rule 16.1 Changing Course

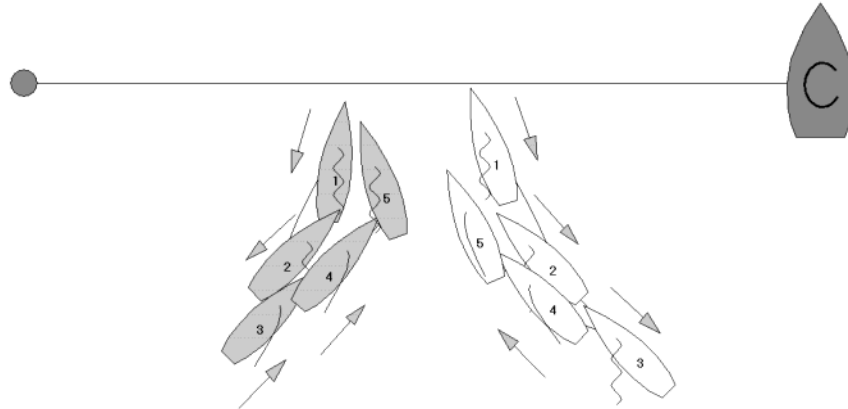

Position 1

Before the start Yellow and Blue are on opposite tacks with both boats head to wind. After some time both begin moving astern. At no time does either move astern by backing a sail.

Position 2

Both reach a close hauled course, but continue moving astern.

Position 3

Blue begins to move forward on a course to pass in front of Yellow. Yellow continues to move astern.

Position 4

Yellow begins to move forward, and from this moment Blue can no longer pass in front of Yellow. Blue immediately luffs to tack.

Position 5

Blue tacks, but before she reaches close hauled Yellow luffs to avoid contact. There is a Y flag. What should the call be?

Answer

Although Yellow did not appear to change compass course between positions 2 and 4, she did change course by reversing the direction in which she was travelling (astern to ahead). Rule 16.1 required Yellow to give room to Blue, which she did by luffing at position 5. Display the green and white flag.

CALL UMP 36

18.2 (c) Rounding and Passing Marks and Obstructions: Giving Room; Keeping Clear: Not Overlapped at the Zone

18.4 Gybing
Definitions Proper Course

Question 1

Yellow is approaching the leeward mark below the layline and is clear ahead of Blue at the zone. Very shortly thereafter Blue becomes overlapped outside and to windward of Yellow. At position 5 Blue displays her Y-flag. What should the call be?

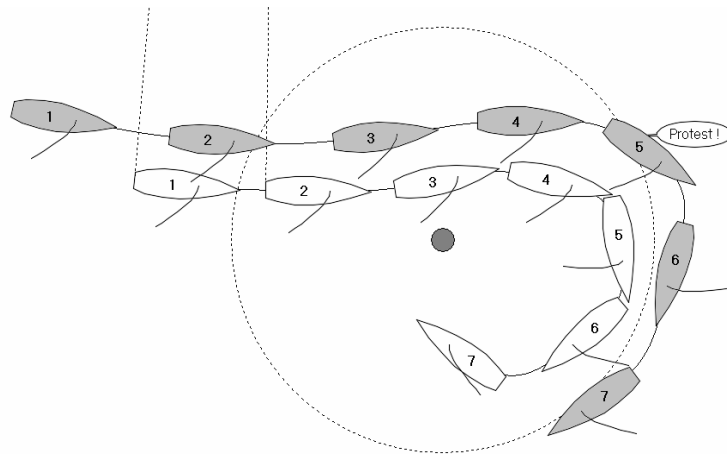

Answer 1

Yellow is clear ahead when she enters the zone. Rule 18.2(c) applies and Blue must keep clear. When Blue becomes overlapped on the outside, she is also required to give room to Yellow. Blue keeps clear and gives room.

From the moment the boats overlap until Yellow gybes, rule 18.4 also applies and Yellow shall sail no farther from the mark than her proper course. The umpires must consider factors such as the type of boat, current, wind strength and waves to decide whether Yellow complies with this rule. If the umpires decide that Yellow sails farther from the mark than she would in the absence of Blue while rule 18.4 applies, then Yellow breaks rule 18.4. Penalize Yellow. If not, display the green and white flag.

Question 2

Would the call be different if Yellow was having a problem lowering her spinnaker?

Answer 2

No. Neither the room that has to be given by Blue nor the course that must be sailed by Yellow is changed by unseamanlike boat handling.

CALL UMP 37

Rule 11 On the Same Tack, Overlapped

Rule 16.1 Changing Course

Rule 18 Rounding and Passing Marks and Obstructions

Question 1

In the pre-start, blue and yellow are overlapped on port tack, with Yellow as the leeward, right of way boat. They approach a continuing obstruction on courses that make it clear that Yellow is the inside boat, or at an angle of approximately 90 degrees to the shoreline so that it is unclear which boat will be the inside boat when they reach the obstruction. Yellow begins to luff or maintains her course and Blue keeps clear. When Yellow is approximately one and a half lengths from the obstruction she suddenly bears away and passes the obstruction to port leaving Blue clear astern. There is a Y flag. What should the call be?

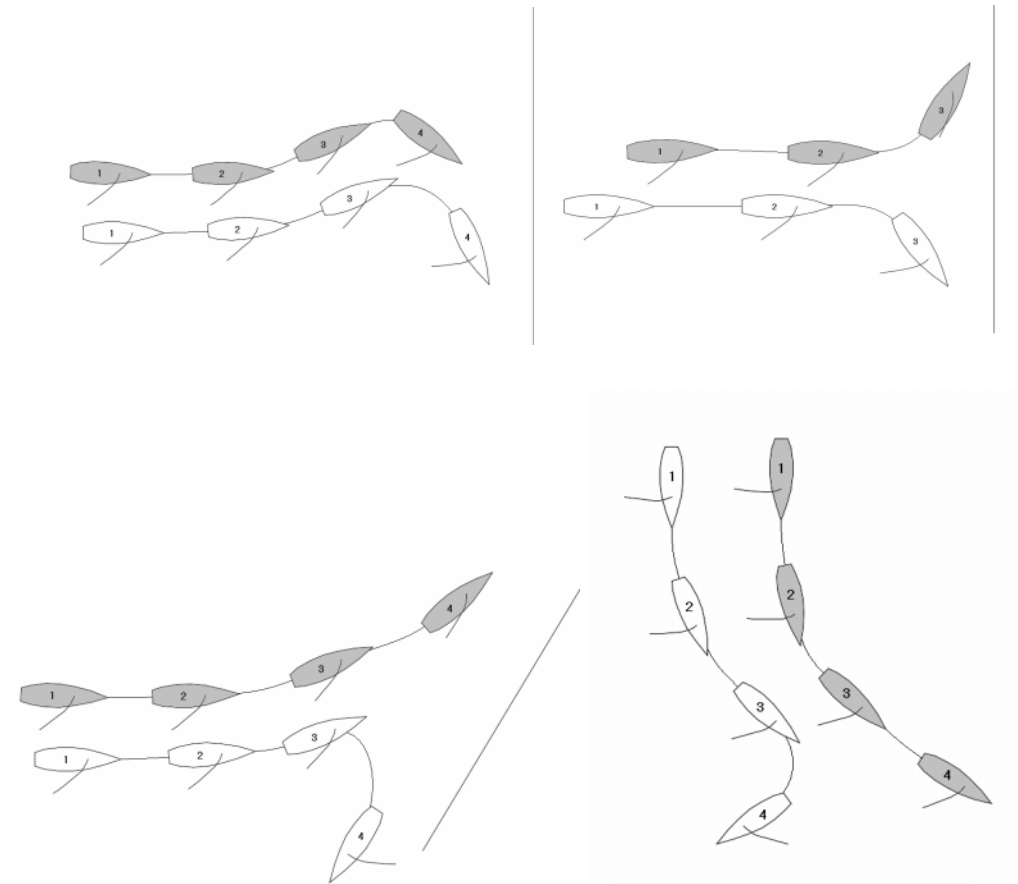

Answer 1

Rule 11 applies, and rule 18.2(a) applies when it becomes clear that the boats are about to pass the obstruction on the same side. Yellow has right of way and can

choose to luff or bear away as she pleases provided she complies with rule 16.1. If Yellow and Blue bear away to pass the obstruction to port, Yellow must give room to Blue while the boats are overlapped. If Blue becomes clear astern, she must comply with rule 18.5. In the situations shown, no rules are broken. Display the green and white flag.

Question 2

In the pre-start, Blue and Yellow overlapped on port tack approach the outer end of a dock. Before the boats are about to pass the obstruction on the same side, Yellow, to leeward, luffs slightly and Blue keeps clear. Yellow suddenly bears away, leaving the obstruction to port. Blue leaves the obstruction to starboard. There is a Y flag. What should the call be?

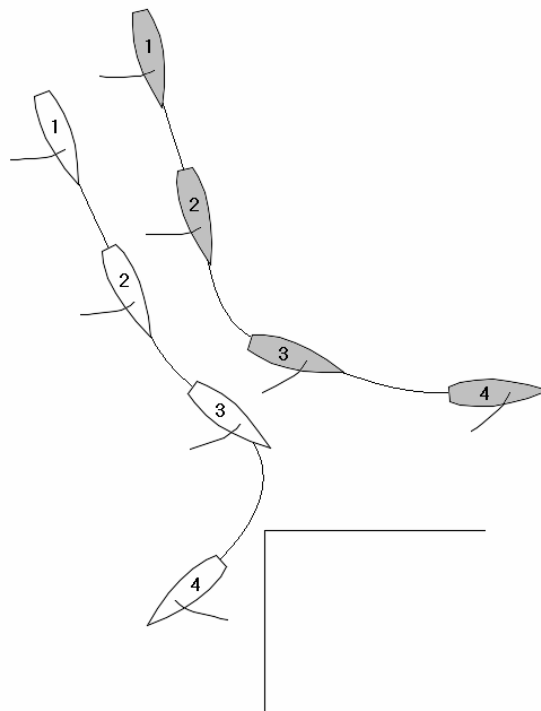

Answer 2

Yellow has right of way and is not the outside boat. Therefore, she can choose to luff or bear away as she pleases provided she complies with rule 16.1. Display the green and white flag.

CALL MR 1

Rule C4.1 **Requirements Before the Start**
Rule C4.2 **Requirements Before the Start**

Question 1

Blue is not outside her assigned end of the starting line at the preparatory signal. As a result Yellow is able to prevent her from crossing the line within the two-minute period. Blue did not cross the line from the course side before starting. What should the umpires do?

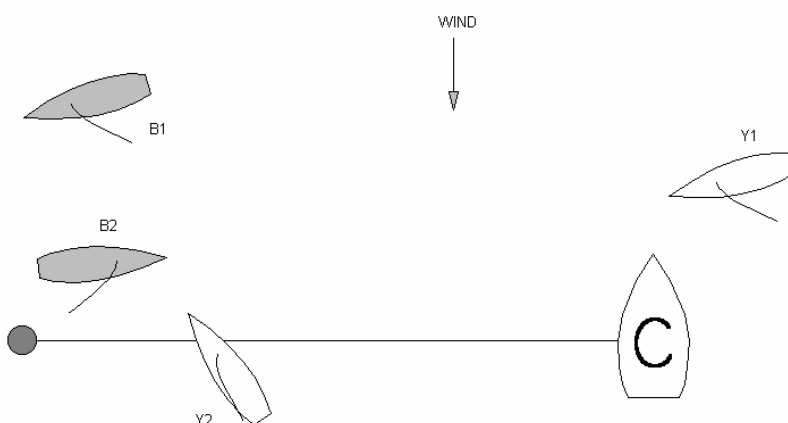

Answer 1

Impose two penalties on Blue. One is for breaking rule C4.1, because she was not outside her assigned end; the other is for breaking rule C4.2, because she did not cross the line from the course side within the two-minute period. These rules were broken in two separate incidents, and therefore each requires a penalty.

Question 2

If a boat has not crossed within the two-minute period, is she still obligated to cross before starting?

Answer 2

No. Although she has broken rule C4.2, there is no requirement that she cross the line after the two-minute period has ended.

CALL MR 2

Rule C8.1(a) Penalties Initiated by Umpires: Rule Changes
Rule C9.3 Other Proceedings

Question

The preparatory signal for a match is made before the umpires have arrived in the course area. It is evident to the race committee on the starting line that Yellow has failed to meet a pre-start requirement (rule C4). May the race committee initiate a post-race hearing?

Answer

No. Such a matter is included under rule C9.3 and only the umpires may take action.

Similarly, if the umpires had been present and they had not signalled a penalty, again no further action could be taken.

CALL MR 3

Rule C7.2 **Penalty System: All Penalties**
Rule C7.3 **Penalty System: Penalty Limitations**

Question

A boat that has been penalized during the pre-start is reaching down the line just before starting. At the starting signal she luffs just enough to cross the starting line and before becoming close-hauled, she bears away, gybes, and sails off on a close-hauled course on the other tack. Has she taken the penalty as required by rule C7?

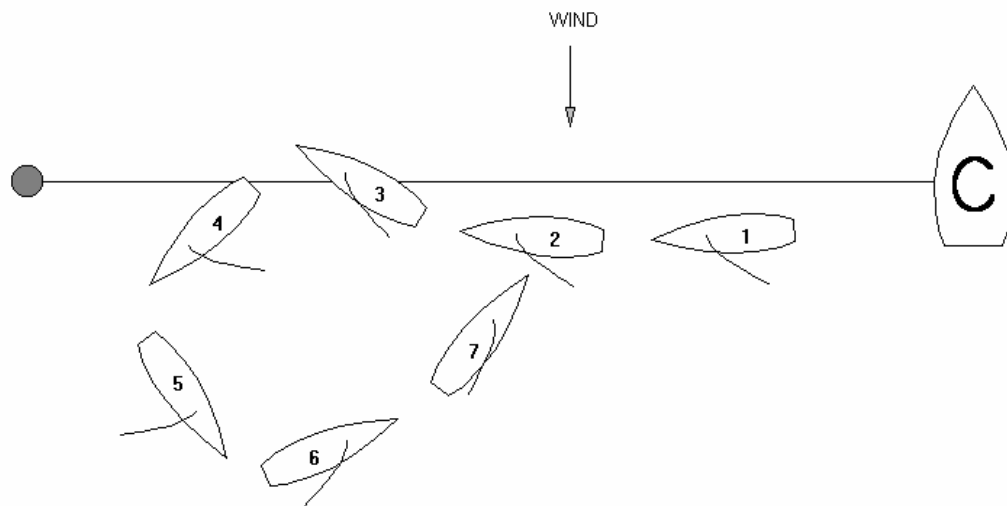

Answer

Yes. The boat was required to start before taking her penalty, but she did not have to begin taking it from a close-hauled course.

CALL MR 4

Rule C2.10 Changes to the Rules of Part 2—interfering with a boat taking a penalty

Rule C2.11 Changes to the Rules of Part 2—when boats in different matches meet

Question 1

Just after starting, Yellow, on port, bears away and gybes to take a penalty. Blue, also on port, but on a track to leeward of Yellow, tacks to starboard, and as a result is on a collision course with Yellow. Yellow is forced to change course to pass behind Blue before completing her penalty and Y-flags. What should the call be?

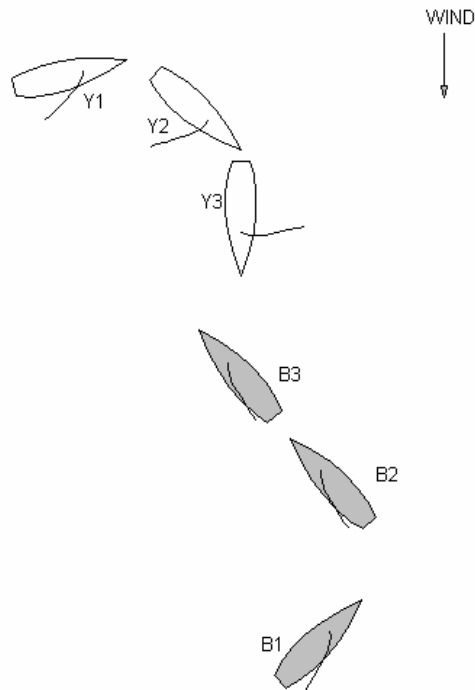

Answer 1

Green and white flag. The 'except when sailing a proper course' phrase in rule C2.10 permits Blue to interfere with Yellow, provided Blue does not break rule 16.1. She has a choice of proper courses and may therefore choose one that will maximise her interference with Yellow. Sailing on either tack can be a proper course.

Question 2

Within the meaning of rule C2.11, if Blue is sailing a proper course, is she permitted to disadvantage Green in a different match?

Answer 2

Yes. When the umpires are satisfied that Blue sailed a proper course, this is consistent with trying to win her own match, by definition, and breaks no rule.

If the umpires are satisfied that the boat's actions were not intended to help her in her own match, but were intended to affect the results of the other match, then Blue breaks rule C2.11. Green may Y-flag under rule C6.1(a).

Question 3

Approaching a leeward mark, Blue is close astern of Green, but they are racing in different matches. Blue luffs to blanket Green, slows her down, and gains an inside overlap. Green must therefore give room to Blue and does so. Has Blue broken rule C2.11?

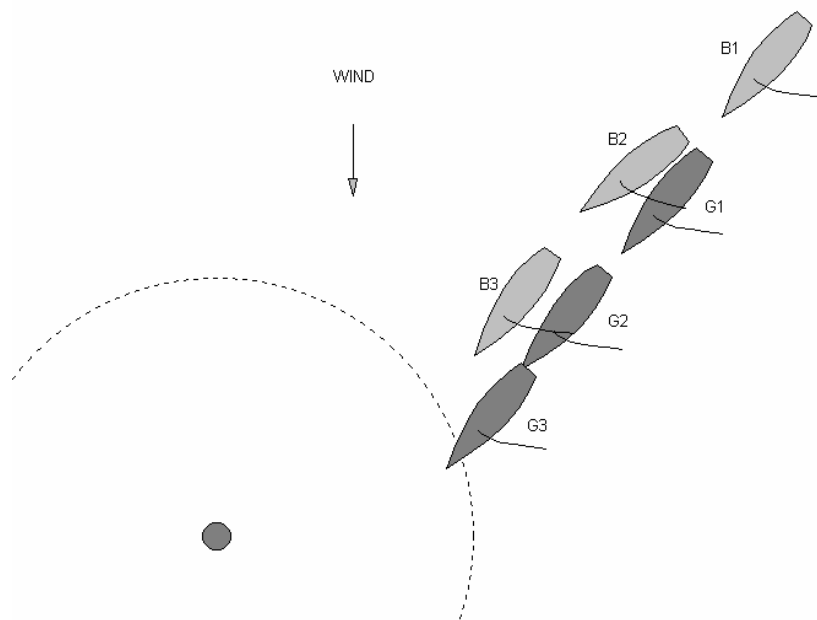

Answer 3

No. Although Green is definitely disadvantaged by Blue's actions, Blue's actions helped her to round the mark in the shortest possible time, and were therefore 'consistent with ... trying to win her own match'. See Answer 2.

CALL MR 6

Rule 28 Sailing the Course
Rule C2.1 Changes to the Definitions—definition Finish

Question 1

When a boat delays taking her penalty until the finish, is she allowed to take it around the finishing mark?

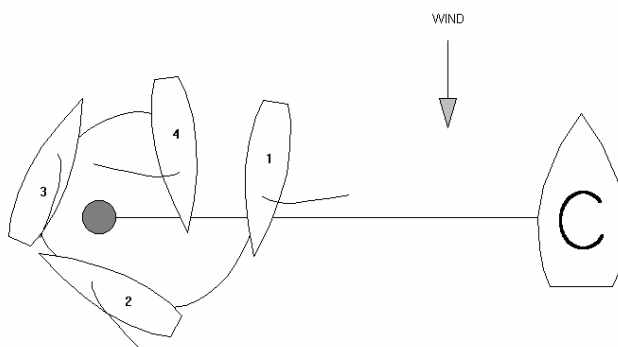

Answer 1

Yes. Although she sails through the finishing line, she does not finish because she has not yet taken her penalty; see Definition of Finish (rule C2.1). Her penalty is to tack ‘ . . . and as soon as reasonably possible, bear away to a downwind course’ in accordance with rule C7.2(a)(2). See also rule C7.2(d).

Question 2

Did she comply with rule 28, Sailing the course?

Answer 2

Yes. Rule 28 requires that ‘a string representing her wake’ would ‘pass each mark on the required side’, which it did. The rule does not prohibit a boat from rounding a finishing mark (or any other mark) even though as a result her wake would pass it on the required side twice.

CALL MR 7

- Rule 14** **Avoiding Contact**
- Rule 60.3(b)** **Right to Protest (by protest committee)**
- Rule 62.1(b)** **Redress (physical damage)**
- Rule C6.1(b)** **Protest Limitations**
- Rule C8.3(a)** **Penalties Initiated by Umpires**
- Rule C8.4** **Penalties Initiated by Umpires**

Question

While sailing under spinnakers, there is contact between Yellow and Blue, and Blue receives a small hole in her spinnaker. Yellow is at fault, and is penalized. On a later downwind leg the hole in Blue's spinnaker becomes a major tear. The spinnaker loses all pressure and Yellow is able to pass Blue. What action is available?

Answer

- (a) The umpires could further penalize Yellow as a penalized boat that has 'gained an advantage by breaking a rule after allowing for a penalty'. Although there has been a delay between the taking of the penalty and the gaining of the advantage, the umpires may still act under rule C8.3(a), if they are satisfied that the spinnaker tear is the result of the original rule breach.
- (b) The umpires could initiate a post-race hearing under rule C8.4 to investigate whether rule 14 was broken.
- (c) In accordance with rule C6.1(b), Blue can red-flag under rule 14, because of damage resulting from contact. The protest committee would need to consider whether the flag was displayed at the first reasonable opportunity after the tear developed.
- (d) Blue could request redress under rule 62.1(b) or redress could be considered under rule 60.3(b).

CALL MR 8

Rule C5.6 **Signals by Umpires - incorrect penalty**
Rule C7 **Penalty System**

Question

Yellow is required to take a tack penalty. May she take it by luffing until she passes head to wind, then turn back to a close-hauled course on her initial tack?

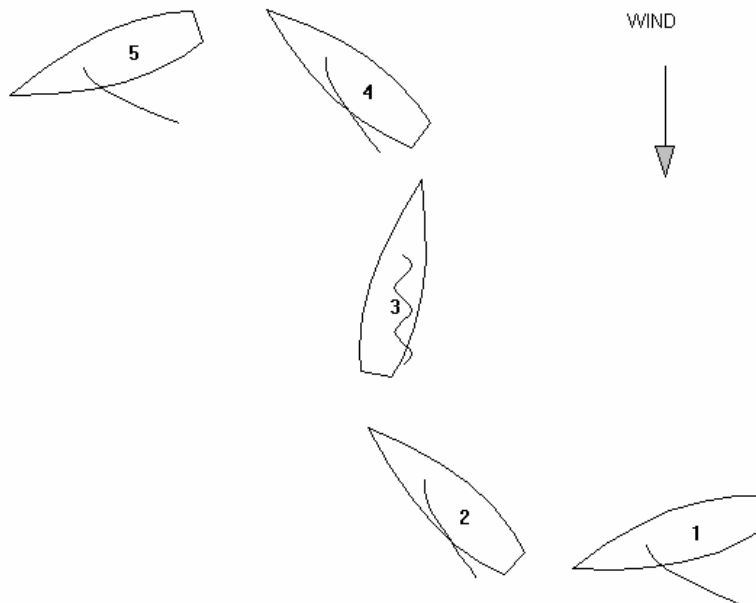

Answer

No, for the purpose of taking a penalty, tacking is to change course from close-hauled on one tack, through head to wind, to close-hauled on the other.

As soon as Yellow passes head to wind rule 13 applies and she must keep clear. Although rule C7.4(a) states that 'a boat with an outstanding penalty that is on a leg to a leeward mark or the finishing line and passes head to wind, is taking a penalty', a boat attempting a penalty in the manner described does not comply with rule C7.2(a)(2) and the umpires shall signal that the boat is no longer taking a penalty and that the penalty remains.

CALL MR 10

Rule 18.2(a) Rounding and Passing Marks and Obstructions: Giving Room; Keeping Clear

Rule 31.1 Touching a Mark

Rule 64.1(b) Penalties and Exoneration

Rule C6.1(a) Protests and Requests for Redress by Boats

Rule C8.1(b) Penalties Initiated by Umpires, Rule Changes

Rule C8.2 Penalties Initiated by Umpires

Question

Blue and Yellow are rounding a mark and Yellow touches it. Neither boat Y-flags. The umpires see Yellow hit the mark, but in their judgement Blue did not give Yellow sufficient room to pass the mark. Should they take any action?

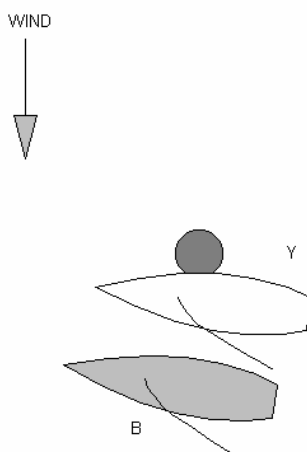

Answer

The umpires should give no signal. Although Blue broke rule 18.2(a), she cannot be penalized because no boat protested, and rule C8.2 does not permit umpires to initiate a penalty when a boat breaks a rule of Part 2.

Yellow broke rule 31.1 by touching the mark. However, rule C8.1(b) makes it clear that she is exonerated under rule 64.1(b).

CALL MR 11

Rule C9.3 Other proceedings

Question

At the end of a downwind leg, just as Blue reaches the two-length zone, Yellow hails 'Overlap', but Blue has just seen the wing boat signal the umpires that there was no overlap. May Blue rely on the wing boat's signal and thereby decide to deny room to Yellow?

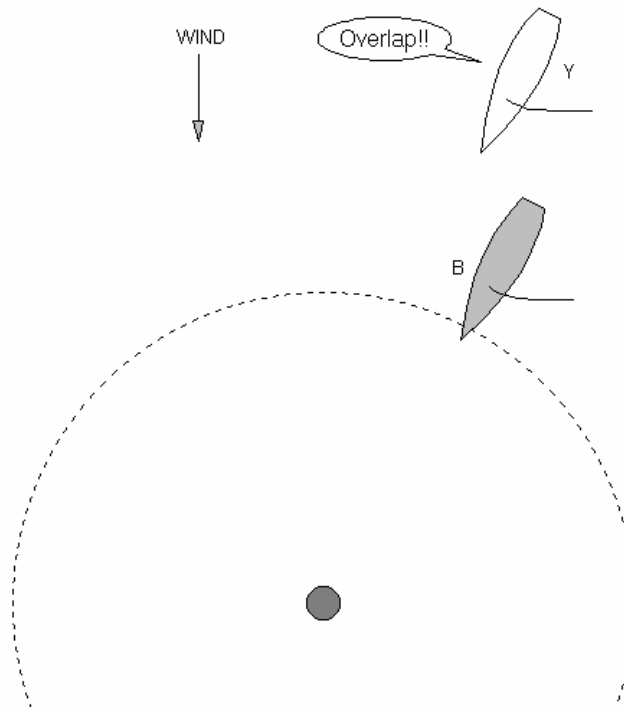

Answer

No. Competitors who use such signals take a considerable risk. Decisions are made by the umpires, not the wing boats, and an umpires' decision may not be based on the wing boat's signals.

The same principle applies to signals made by onboard observers.

CALL MR 12

Rule 10	On Opposite Tacks
Rule 15	Acquiring Right of Way
Rule C2.8	Changes to the Rules of Part 2—keeping clear while taking a penalty
Rule C7	Penalty System

Question

Yellow on starboard and Blue on port are sailing towards each other. When they are about to meet, Yellow is penalized and required to take an immediate penalty (the penalty was either a red flag penalty or her second penalty). When does the right of way change?

Answer

The right of way does not change until it is clear that Yellow is taking her penalty.

This is when she passes head to wind or the foot of her mainsail crosses the centreline, as appropriate.

Blue will acquire right of way by the action of Yellow and so Blue will not need to give room to Yellow under rule 15.

CALL MR 13

Rule C8.3(c) Penalties Initiated by Umpires—breach of sportsmanship

Question

After the umpires signal their decision in response to a boat's Y flag, persons on one of the boats make it clear that they are unhappy with the decision. Should the umpires impose a penalty under rule C8.3(c) for a 'breach of sportsmanship'?

Answer

This depends on the words, the manner in which they are spoken, and any other related actions of the crew of the boat. If they merely express unhappiness or disappointment, or that in their opinion the decision was wrong, then a penalty is not appropriate. However, if the total effect is to convey that the umpires are incompetent, or are prejudiced against the penalized boat, a penalty may be justified, whether the meaning is directed only at the umpires or also to others nearby. If the meaning is clearly insulting to the umpires, a penalty should be imposed.

CALL MR 14

Rule C6.5 Protests and Requests for Redress by Boats: Umpire Decisions

Question

Immediately following an incident Yellow Y-flags. Before the umpires signal their decision, there is a second incident and Blue Y-flags. How should the umpires signal their decision?

Answer

The umpires should make two separate decision signals, in the order they were signalled by the boats, even when a green and white flag signals the decision for each protest.

CALL MR 15

- Rule 60.3(b) Right to Protest (actions by the protest committee)**
- Rule 62.1(a) Redress**
- Rule C6.5 Protests and Requests for Redress by Boats: Umpire Decisions**
- Rule C9 Requests for Redress: Other Proceedings**

Question 1

Blue Y-flags, but the umpires make no signal. Both boats finish the race, Blue losing it. May she seek redress under rule 62.1(a) because of the umpires' failure to signal a decision?

Answer 1

No. Rule C9.3 prohibits any 'proceedings' because of non-action by umpires. 'Proceedings' includes a request for redress.

Question 2

Blue Y flags, but due to engine failure the umpires do not see the incident. What should they do?

Answer 2

Green and white flag. As the umpires were not in position, their only option is to signal 'no penalty'. Further, rule C9.1 prohibits the boat from seeking redress, and rule C9.3 prohibits the umpires from initiating redress under rule 60.3.

CALL MR 16

Rule C7 Penalty System

Question 1

Rule C7.3(c) requires a boat with two penalties to take one of them 'as soon as reasonably possible'. Rule C7.3(d) requires a boat with a red flag penalty to take her penalty 'as soon as reasonably possible'. How must she comply with this requirement when the proximity of another boat or an obstruction, or both, prevent her from luffing or bearing away to begin her penalty tack or penalty gybe?

Answer 1

She may delay bearing away (luffing, when the penalty is to tack) until there is no likelihood of her making contact with the other boat or the obstruction, but when the obstruction is continuing or when the other boat obstructs her and by sailing a parallel course continues to obstruct her, she must tack (or gybe) to get clear or she may reduce speed until she is no longer obstructed by the other boat. Should the other boat then tack to prevent her from taking the penalty, she must again tack to further attempt to get clear.

Question 2

A boat with a penalty is penalized again. Part of the penalty would be within two of her hull lengths of a rounding mark were she to take the penalty immediately. What is she required to do before taking a penalty?

Answer 2

She may sail the course she would have sailed without the second penalty until she can take the second penalty without any of the penalty being taken within the two-length zone. She must then take the penalty.

Question 3

A boat with a penalty is penalized again while her spinnaker is set. What is she required to do?

Answer 3

A boat is required to take the penalty as soon as reasonably possible, even though her spinnaker is set. She must lower the spinnaker head below the main boom gooseneck and take her penalty without delay.

CALL MR 17

- Rule C5** **Signals by Umpires**
Rule C6.5 **Protests and Requests for Redress by Boats: Umpire Decisions**
Rule C7.2(b) **Penalty System: All Penalties**

Question 1

Yellow Y-flags. Blue takes a penalty as soon as she sees Yellow's Y flag and before the umpires signal a decision. What should the call be?

Answer 1

Green and white flag. Rule C7.2(b) allows a boat to take a penalty before being signalled to do so. Rule C5.1 says the green and white flag means 'No penalty'. Here no penalty is imposed because it was already taken.

Question 2

Would the answer be different if Yellow had an outstanding penalty?

Answer 2

No. The umpires would green and white flag and Yellow's penalty would remain.

Question 3

Near the end of a windward leg the umpires decide to penalize Blue but delay signalling her until she has rounded the mark. However, she takes the penalty before rounding the mark. Is this allowed?

Answer 3

Yes — see Answer 1. However, under rule C7.3(b) she is not allowed to take any part of a penalty within two of her hull lengths of a rounding mark.

Question 4

Yellow, with a penalty, breaks a right-of-way rule, is protested by Blue, sees Blue's Y flag and takes her penalty before being signalled by the umpires. At the time she sees the Y flag, she is rounding a mark. Should she take the penalty appropriate to the leg she is on or the one appropriate for the time of the umpire's signal?

Answer 4

A boat taking a penalty before it is signalled shall take the penalty appropriate to the leg she is on.

CALL MR 18

- Rule C2.9** Changes to the Rules of Part 2—interference by a boat not racing
- Rule C8.4** Penalties Initiated by Umpires - informing the protest committee

Question

After a race the umpires receive a report from a reliable observer that a boat broke rule C2.9 before her race by interfering with a boat that was racing. May the umpires initiate a hearing to consider penalizing her?

Answer

No. As this concerns a rule of Part 2, a hearing cannot be initiated by the umpires. Only the boat that was interfered with can take action by displaying a Y flag at the time of the incident.

CALL MR 19

- Rule C6.5** **Protests and Requests for Redress by Boats: Umpire Decisions**
Rule C8.4 **Penalties Initiated by Umpires—informing the protest committee**
Rule C9.3 **Other Proceedings**

Question 1

The umpires penalize a boat for breaking a right-of-way rule and signal accordingly. Shortly thereafter the umpires decide they have made an error. May they cancel their signal, by displaying a green and white flag, or by displaying the other boat's signal, or by hailing or some other means of communication?

Answer 1

No. There is no provision in Appendix C to change or amend decisions or signals. When a penalty signal is displayed, the boat is bound by rule C5 to take the appropriate penalty.

Question 2

Would the answer be the same if the umpires displayed a green and white flag when they intended to display a boat's signal?

Answer 2

Yes.

CALL MR 21

Definitions Keep Clear
Definitions Overlap

Question 1

If a person extra to the crew is carried onboard a boat, such as an 'observer' (umpires' assistant) or a cameraman, should the person or the equipment carried be considered as a part of the boat's 'hull or equipment in normal position' for the determination of overlaps or contact between two boats?

Answer 1

No. Such a person is not a part of the boat.

Question 2

Fixed cameras and/or their fixed brackets, placed by or under the direction of the race committee, may project beyond the stern of the boat. Should a camera or its bracket be considered as part of the boat's 'equipment in normal position' for the determination of overlaps or contact between two boats?

Answer 2

Yes, when fixed to the boat, cameras or brackets become part of the boat's equipment. Another example would be antennas for radio transmission.

Question 3

Flags carried by boats often project beyond the hull line astern or to leeward of the boats. Should they be considered as part of the boat's 'equipment in normal position' for the determination of overlaps or contact between two boats?

Answer 3

No. In match racing flags are not considered to be part of a boat's equipment; the flag staffs are.

CALL MR 22

Rule C2.11 Changes to the Rules of Part 2—when boats in different matches meet

Question

Yellow and Blue are sailing in one match and Red and Green in another. Green meets Yellow on the course and Green is the right-of-way boat. Is it permissible for Green to change her course so that Yellow has no need to change course to keep clear?

Answer

Yes, provided that the change of course by Green is ‘consistent with complying with a rule or trying to win her own match.’

If Green clearly disadvantaged herself by her course change, then she would have broken rule C2.11.

CALL MR 23

Rule C2.11 Changes to the Rules of Part 2—when boats in different matches meet

Rule C6 Protests and Requests for Redress by Boats

Question

Yellow and Blue are in one match with Yellow ahead of Blue. Blue sees an incident between Yellow and Green (a boat in the match ahead) in which Yellow seems to be breaking a rule of Part 2. Green does not Y-flag. What action can Blue take?

Answer

None. Rule C6.1(a) and 6.2(b) prevent Blue from Y-flagging Yellow because she was not involved in the incident.

Rule C6.1(b) prevents Blue from red-flagging Yellow.

CALL MR 24

Rule 2	Fair sailing
Rule C2.7	Changes to the Rules of Part 2 — room to tack
Rule C8.4	Penalties Initiated by Umpires — informing the protest committee

Question 1

Rule C2.7 requires clear and repeated arm signals, in addition to hails. If there is an arm signal but no hail from Yellow, what action should the umpires take

- a) if Blue Y-flags?
- b) on their own initiative?

Answer 1

- a) When the umpires are certain that no hail was made, then the signal for room to tack has not been made. (The umpires may be certain there was no hail if they have had no difficulty hearing other calls from a similar position.) For the purpose of the rules of Part 2 they should act as if there has been no signal.
- b) The umpires may decide that Yellow has broken rule C 8.3(b) or (c) and penalize her. They could also, in an extreme or repeated case, initiate a hearing under rule 2, Fair Sailing.

Question 2

If there is a hail but no arm signal, is the answer the same?

Answer 2

Yes.

CALL MR 25

- Rule 10** **On Opposite Tacks**
Rule 19 **Room to Tack at an Obstruction**
Rule C8.1(b) **Penalties Initiated by Umpires—exoneration**

Question 1

Blue is matched against Yellow and Red against Green. On a windward leg Blue is close-hauled on starboard tack, Yellow and Green are overlapped, both close-hauled on port. Yellow, to leeward of Green, cannot tack and clear Green. Blue and Yellow are on a collision course. Yellow hails and signals for room to tack. Green does not respond, Yellow is unable to tack, Blue is forced to change course to keep clear. Blue and Yellow Y-flag. What should the umpires do?

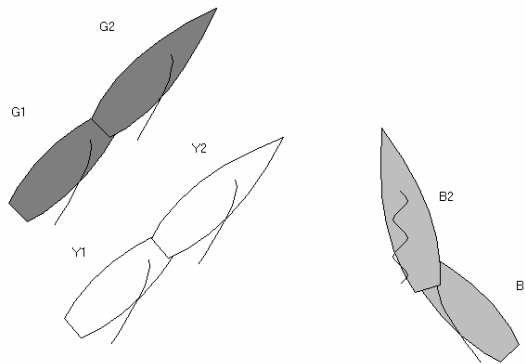

Answer 1

If the umpires of the match between Blue and Yellow are certain that Green broke rule 19 they should display a green and white flag indicating that no penalty is imposed on Yellow or Blue. They should advise the umpires for Green's match, that Green should be penalized. Rule C8.1(b) permits the umpires to exonerate Yellow without a hearing.

Question 2

If Yellow does not Y-flag, would the answer be different?

Answer 2

No. The umpires response would be the same. The umpires may also consider penalizing Green under rule C8.3(b) or (c).

CALL MR 26

Rule C7.2(a)(2) Penalty System: All Penalties - when on a leg of the course to a leeward mark or the finishing line

Question

When is a boat on a downwind course?

Answer

A boat is on a downwind course when she is sailing a course more than 90 degrees away from the wind.

CALL MR 27

- Rule 32.1(e)** Abandoning After the Start
Rule 62 Redress
Rule C9.2 Requests for Redress—Official boat interfering with competing boat
Rule C9.3 Other Proceedings—following action or non-action by umpires

Question

Under what circumstances should a match in progress be abandoned?

Answer

After the preparatory signal a match should be abandoned only when the umpires and race committee are sure that a claim for redress would be upheld were the adversely affected boat to lose the match or for reasons of safety. It is then preferable to abandon the match immediately. The following are examples:

- a) a late or incorrect recall signal.
- b) serious interference with a competing boat by an umpire or other official boat.

During the preparatory period the match may also be postponed.

A match should not be postponed or abandoned due to an incorrect umpire signal. In this case rule C9.3 applies.

CALL MR 28

Rule C2.8 Changes to the Rules of Part 2—keeping clear while taking a penalty
Rule C7 Penalty System

Question 1

Blue and Yellow are sailing downwind on port tack. Blue has an outstanding penalty. She luffs, passes head to wind, and bears away to a close-hauled course on starboard tack. Yellow changes course to avoid a collision before Blue achieves a downwind course. Blue continues to bear away and achieves a downwind course. Both boats Y-flag. What should the call be?

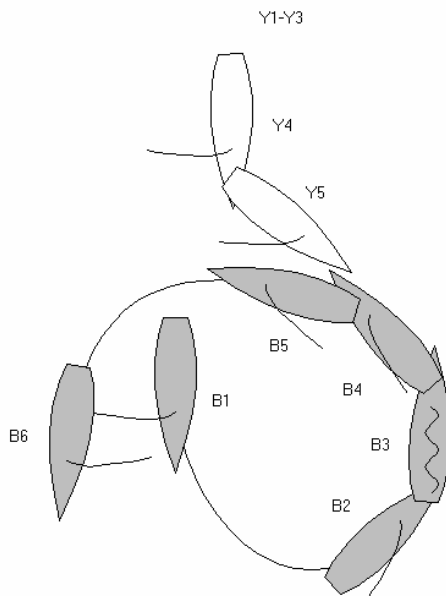

Answer 1

Signal that Blue has completed a penalty and then penalize Blue again. Blue did comply with rule C7.2(a)(2) and so completed a penalty. However, before returning to a downwind course she broke rule C2.8.

CALL MR 29

Rule C2.1 Changes to the Definitions - definition Finish
Rule C5.6 Signals by Umpires
C7.4(b) Penalty System: Taking and Completing Penalties

Question

Blue has a penalty outstanding as she approaches the finishing line. She lowers her spinnaker, luffs, passes head to wind, returns to a close-hauled course on the other tack, reverses her mainsail and sails backwards across the finishing line, now above close-hauled. Has she finished?

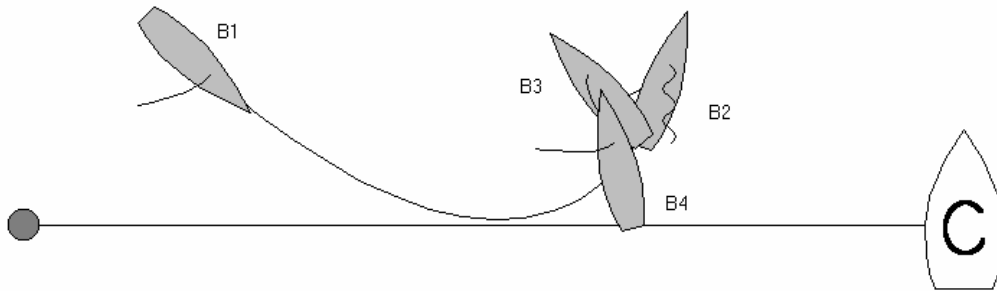

Answer

No. Blue cannot finish until she has taken her penalty. She has not borne away to a downwind course as required by rule C7.2(a)(2). The umpires will signal as required in rule C5.6 that the boat is no longer taking a penalty and that the penalty remains.

CALL MR 30

- Rule 11** **On the Same Tack, Overlapped**
Rule 17.1 **On the Same Tack: Proper Course**
Rule C7 **Penalty System**
Rule C8.3(b) **Penalties Initiated by Umpires—deliberately breaking a rule**

Question 1

Blue, to windward, fails to keep clear of Yellow to leeward. Yellow protests and Blue is penalized. Some time later Yellow protests again. When should the umpires consider that a rule is broken a second time?

Question 2

Blue has been penalized for sailing above a proper course, continues to do so and there is another protest from Yellow. When should the umpires consider that a rule is broken a second time?

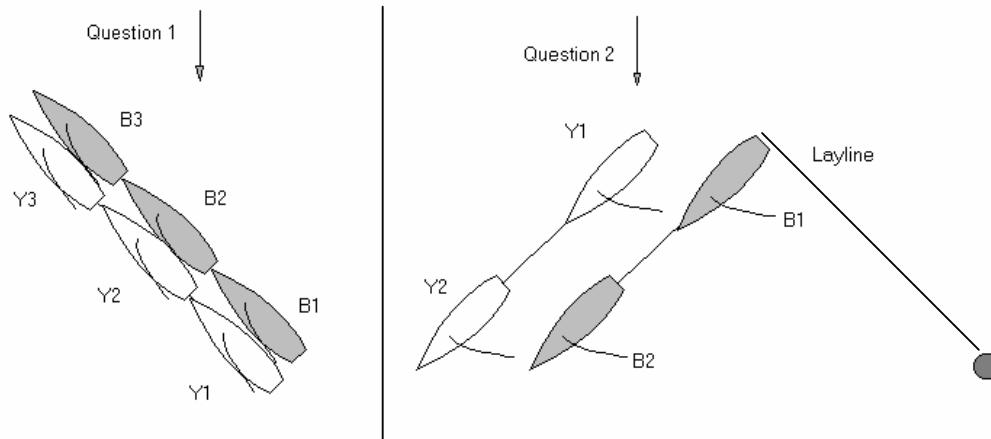

Answer 1 and 2

When the umpires are satisfied that Blue could have taken action to stop breaking the rule after the first penalty is signalled, but fails to do so, then they consider that the rule is broken a second time. The umpires may also decide that the second breach is deliberate and initiate a penalty without any Y flag being flown.

CALL MR 31

Rule C8.3(b) Penalties Initiated by Umpires—deliberately breaking a rule

Question

How will the umpires decide if a rule was broken deliberately?

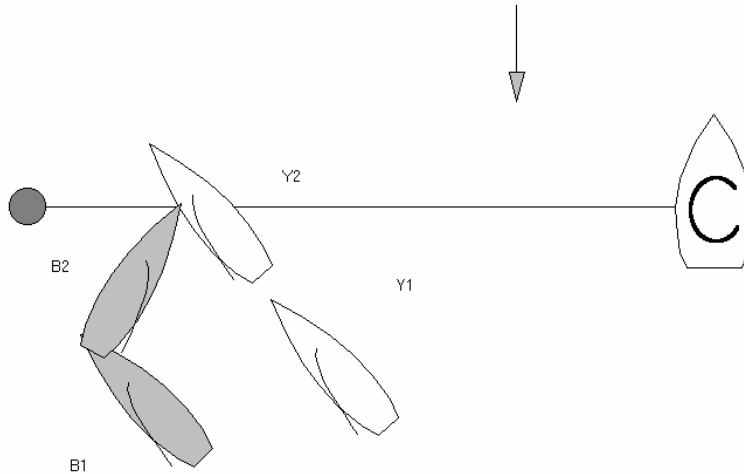

Answer

There is no complete clear cut answer, but rather a sliding scale of likelihood. The umpires are likely to conclude that a rule was broken deliberately when:

- the situation has built up for some time rather than occurred instantaneously;
- there is a potentially match-winning tactical gain from breaking the rule;
- the infringement does not seem to be a simple misjudgement.

Examples could be:

- breaking a rule to avoid being OCS (windward boat bears down on leeward boat);
- Blue cannot lay the pin and tacks onto port (see Diagram above);
- barging at a starting mark;
- denying an inside boat room at the mark.

CALL MR 32

Rule C7.2(a)(1) Penalty System: All Penalties - penalties to a windward mark

Rule C7.2(a)(2) Penalty System: All Penalties - penalties to a leeward mark or the finishing line

Question

The required penalties vary depending upon whether a boat is sailing 'to a windward mark' or 'to a leeward mark'. Because a boat has sailed beyond a mark, or because of a new wind direction, a boat could be sailing free to a mark that was intended to be a windward mark, or sailing close-hauled to a mark that was intended to be a leeward mark. What penalties are then required?

Answer

A boat is to be considered to be sailing to a windward mark or to a leeward mark at all times when sailing to a mark that has been described in the sailing instructions as a windward or leeward mark. The description could be expressed in words, or shown by a diagram indicating wind direction, or by designating marks as either 'Mark W' or 'Mark L'.

In the usual match racing course configuration with two upwind and two downwind legs, a boat sailing the first and third legs is considered to be sailing 'to a windward mark', and when sailing the second leg is considered to be sailing 'to a leeward mark', irrespective of the boat's heading or the wind direction.

Because a boat may have sailed beyond a mark, or because of a new wind direction, it would be possible for the boat to be sailing close-hauled yet be on 'a leg of the course to a leeward mark', or be sailing free on 'a leg to a windward mark'.

CALL MR 33

Rule C7 **Penalty System**
Rule C8.3 **Penalties Initiated by Umpires - gaining an advantage**

Question 1

Yellow is penalized before she starts. Later she and Blue both start on port tack, with Yellow to leeward but approximately four hull lengths ahead of Blue. Yellow bears away, gybes, then luffs to close-hauled on starboard tack. Soon afterward rule 10 requires Blue to change course to avoid Yellow. Has Yellow ‘gained an advantage over the other boat’ in the context of rule C8.3(a)?

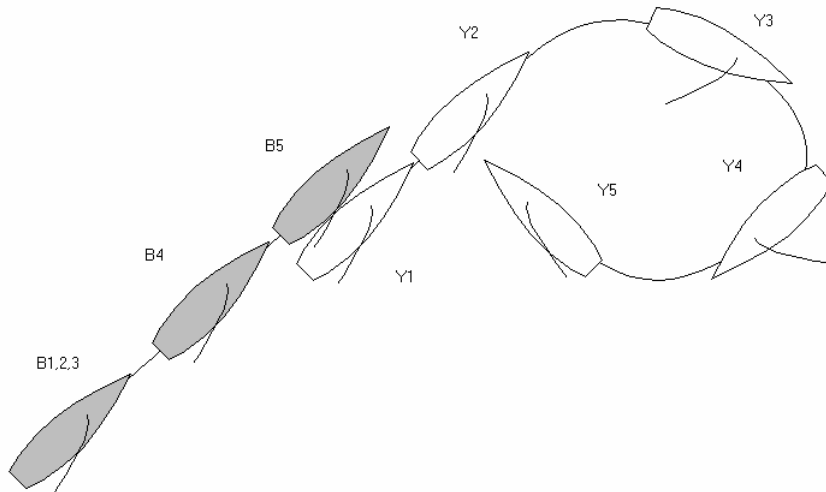

Answer 1

No. Rule C8.3(a) refers to situations in which the advantage that a boat gains from breaking a rule is greater than the disadvantage she suffers by taking the penalty. Here the advantage that the penalized boat gained as a starboard tack boat after taking her penalty is unrelated to the advantage referred to in rule C8.3(a).

Question 2

The boats are close together on a windward leg and one is penalized. After gybing she sails away on the opposite tack and immediately gains from a major wind-shift. Has she ‘gained an advantage’ from the penalty?

Answer 2

No. See Answer 1.

CALL MR 34

Rule 17.1 **On the Same Tack: Proper Course**
Rule C2.6 **Rounding and Passing Marks and Obstructions: Tacking at a Mark**

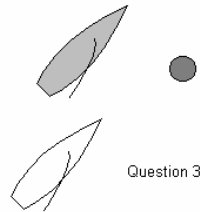
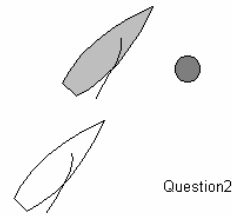

Question 1

Blue completes her tack in the position shown as Question 1. Yellow is clear astern and can avoid an inside overlap by luffing. May Yellow create an inside overlap? What rules apply?

Answer 1

Yes. Yellow may create an inside overlap but rule 18.2(c) applies as if she was clear astern at the two-length zone (See rule C2.6) and she must keep clear of Blue whilst they are rounding the mark. As Yellow established an overlap from astern she is also subject to rule 17.1 and shall not sail above her proper course unless in doing so she promptly sails astern of Blue.

Question 2

Blue completes her tack in the position shown as Question 2. Yellow is clear astern but cannot avoid an inside overlap by luffing. May Yellow create an inside overlap? What rules apply?

Answer 2

Rule C2.6 applies. Yellow may establish an inside overlap and is not required to give Blue room to keep clear as rule C2.6 states that rule 15 does not apply. As Yellow established an overlap from astern she is subject to rule 17.1 and shall not sail above her proper course unless in doing so she promptly sails astern of Blue.

Question 3

Blue completes her tack in the position shown as Question 3. Yellow is overlapped inside. What rules apply?

Answer 3

Rule C2.6 applies. Blue is required to keep clear. Yellow is not required to give Blue room to keep clear as rule C2.6 states that rule 15 does not apply. As the overlap was established before Blue completed her tack rule 17.1 does not apply and Yellow may sail above her proper course.

CALL MR 35

Rule C2.6 Tacking at a Mark

Question

Yellow tacks within the two-length zone and Blue becomes overlapped on the inside. The umpires are not certain Blue could avoid becoming overlapped by luffing.

Yellow displays a Y flag. What should the call be?

Answer

Green and white flag. When the umpires are not certain that Blue could avoid becoming overlapped by luffing, they shall presume that she could not.

CALL MR 36

- Rule C5.3** **Signals by Umpires - red flag penalty**
- Rule C6.5(b)** **Umpire Decisions - red flag penalty**
- Rule C7.3(d)** **Penalty limitations - red flag penalty**
- Rule C8.2** **Penalties Initiated by Umpires**

Question

After starting, Yellow is penalized, and the penalty is signalled with a yellow and a red flag in accordance with rule C5.3 and C6.5(b). After a period of time, the umpires decide that Yellow has not taken the penalty as soon as reasonably possible. What should the umpires do?

Answer

The umpires should penalize Yellow under rule C8.2.

CALL MR 37

- Rule 11** **On the same tack, Overlapped**
Rule 18.2(a) **Rounding and Passing Marks and Obstructions: Giving Room; Keeping Clear**
Rule C2.8 **Changes to the Rules of Part 2 - keeping clear while taking a penalty**

Question

Yellow, ahead of Blue, is taking a penalty around the finishing mark. As Yellow tacks and bears away on port, Blue, approaching the mark on starboard, bears away and gybes to port. There is a Y flag. What should the call be?

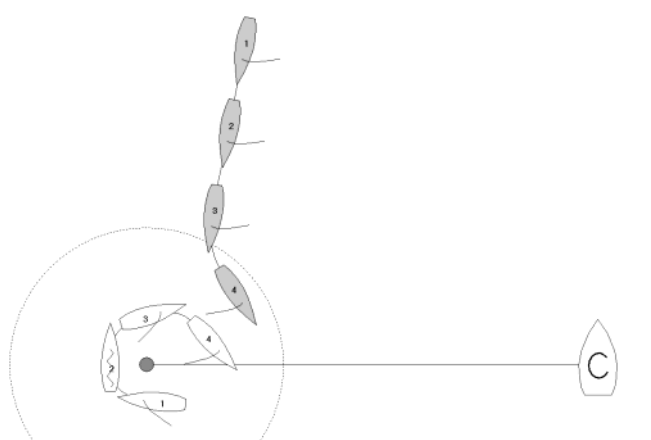

Answer

When Yellow passes head to wind, she begins taking a penalty and must keep clear under rule C2.8 until she completes her penalty by bearing away to a downwind course. In addition, rule 18.2(a) applies, since the boats are overlapped and about to pass the mark on the same required side. An alteration of course by Blue may be either to keep clear of Yellow, or to give Yellow room at the mark, or both.

If Blue is required to alter course before Yellow completes her penalty, Yellow is not keeping clear under rule C2.8 even if Blue is altering course to give room. Signal that Yellow has completed her penalty and penalize Yellow again for breaking rule C2.8. See Call MR 28.

If Blue's alteration of course is not required until after Yellow completes her penalty, display the green and white flag.

CALL MR 38

Rule 19 **Room to Tack at an Obstruction**
Rule C8.3 **Penalties Initiated by Umpires**

Question

Approaching an obstruction, Yellow and Blue are sailing upwind on the same tack. Blue hails and signals Yellow for room to tack. Yellow believes that Blue is sailing below a close-hauled course and she ignores the hail. Both boats protest. What should the call be?

Answer

When the hailing boat is sailing upwind, the hailed boat must always respond to the hail in accordance with rule 19.1(a) or (b). Penalize Yellow. In addition, if Blue hailed for room to tack when it was clear that the requirements in rule 19.1 were not met, then Blue broke rule 19.1. Penalize Blue.

INDEX

- Abandonment: MR 27
advantage gained from penalty: MR 7, 33
anchored boat: UMP 6
approaching a starting mark to start: UMP 10, 13
arm signal: MR 24
avoiding action: UMP 11, 17
- Backing a sail: UMP 2, 35
bear away: UMP 3, 4, 5, 6, 10, 11, 12, 14, 15, 16, 19, 23
continuously: UMP 11
beat: UMP 21
before the start: UMP 6, 10, 11, 13, MR 1, 2, 27
boat:
in another match:
change of course: MR 22
interference: MR 4
proper course: MR 4
nearby: UMP 19
bow: UMP 7, 10, 16, 18, 21
bowsprit-type pole: UMP 21
breach of a rule:
continuing: MR 30
deliberate: MR 24, 25, 30, 31
- Cameras: MR 21
change course: UMP 4, 5, 6, 9, 10, 11, 12, 14, 16, 17, 22, 24, 27, 35, MR 4
clear ahead: UMP 22, MR 34
clear astern: UMP 1, 6, 19, MR 34
close-hauled: UMP 14, 15, 17
course: UMP 11
committee boat: UMP 13
conditions of wind and water: UMP 20
contact (hit, collision): GEN 2, UMP 1, 3, 4, 5, 6, 9, 12, 14, 15, 16, MR 7, 10
course:
change: UMP 4, 5, 11, 12, 16
collision: UMP 14
downwind: MR 26, 28, 29
parallel: UMP 4, 9
side: UMP 13
cross ahead: UMP 14
- Downwind:
leg: UMP 19
course: MR 26, 28, 29
- Entry:
timeliness: MR 1
umpire-initiated penalty: MR 2
equipment: UMP 18
overlapped: MR 21
exoneration: MR 10, 25
- Finish:
downwind: UMP 18
finishing line: UMP 18, MR 6, 29
flags: MR 21
- Gaining an advantage: MR 7, 33
ground: UMP 2
gybe: UMP 6, 10, 19, 22, 36, MR 3, 4, 33
- Hail required: MR 24
head to wind: UMP 5
passing: UMP 11, MR 8, 28, 29
hoisting: UMP 21
hull lengths: UMP 14
- ISAF:
Case 21: UMP 20

Case 24: UMP 1

Keep clear: UMP 1, 3, 4, 5, 7, 9, 11,
12, 14, 16, 17, 22, 24, 29, 30,
32, MR 8, 22, 25, 30, 34, 37

Layline: UMP 17, 19, MR 30

leeward leg: MR 32

loses way: UMP 11

lowering: UMP 21

luff: UMP 1, 5, 9, 10, 12, 14, 16, 17,
24, MR 34

Manoeuvres: UMP 20

passing: UMP 22

pre-start: UMP 21, 27

mark: UMP 17, 19, 24, 27, 29, MR
4, 6, 10

passed: UMP 22

starting: UMP 13

mast: UMP 21

moored boat: UMP 6, 10

moving astern: UMP 2, 35

Normal position: UMP 18, 21

Observers: MR 11, 18

obstruction: UMP 6, 10, MR 16

opposite tack: UMP 11, 12, 14, 16

overlap: UMP 1, 3, 4, 5, 6, 9, 10, 13,
17, 19, 21, 24, 28, 30, MR 30,
34, 35

and cameras etc.: MR 21

over rotating: UMP 5

over standing: UMP 17

Pass:

astern: UMP 11

head to wind: UMP 5, 11

on same side: UMP 10

to windward: UMP 6

parallel course: UMP 4, 9

penalties:

appropriate leg of course: MR 17

around finishing marks: MR 6, 37
as soon as reasonably possible:

MR 16

downwind course

completion of penalty: MR 28, 29

defined: MR 26

gaining advantage: MR 33

interference with another boat:

MR 4, 28

incorrect penalty: MR 29

keeping clear while taking a
penalty: MR 28, 37

leeward leg / mark: MR 32

on windward leg: MR 3

proper course: MR 4

red-flag penalty: MR 12, 16, 36

right of way change: MR 12

spinnaker down: MR 16

starting: MR 3

tacking defined: MR 8

two-length zone: MR 16, 17

windward leg / mark: MR 32

pole:

bowsprit-type: UMP 21

spinnaker: UMP 21

postponement: MR 27

prevailing conditions: UMP 13, 20

proper course: UMP 9, 17, 19, 36,
MR 30, 34

Race committee: UMP 18, MR 2,
27, 29

recall: UMP 13, MR 27

red-flag protest: MR 7

redress: MR 7, 15, 27

required side: UMP 13, MR 6

responding: UMP 5, 14

right-of-way: UMP 3

right-of-way boat: UMP 4

risk of damage: UMP 20

room: UMP 1, 3, 4, 5, 9, 10, 11, 13,
14, 15, 16, 20, 24, 27, 32, 33,
37, MR 10, 11, 31, 34, 37

Sailing downwind: UMP 13, MR 28

seamanlike: UMP 14, 20, 29

side by side: UMP 5

spectator boat: UMP 6

speed: UMP 13

spinnaker: UMP 21, 28, 33

guy: UMP 18

halyard: UMP 18

pole: UMP 21

sheet: UMP 18

sportsmanship: MR 13

start:

after: MR 4, 27

before: UMP 6, 10, 13, MR 1, 33

pre- : UMP 21, MR 2, 3

starting line: UMP 13, MR 1, 3

mark: UMP 13

signal: UMP 13, MR 1,3

stern: UMP 1, 5, 10, 12, 16, MR 21

Tack: UMP 3, 6, 11, 14, 15, 17, 20,
22, 24

time: UMP 13

touching a mark: MR 10

transom: UMP 7

two-length zone: UMP 22, 24, MR
11, 16, 17, 35

Umpire initiated penalties:

deliberate breach: MR 24, 25, 30,
31

entry requirements: MR 1, 2

exoneration: MR 10, 25

gaining an advantage: MR 7, 33

informing the protest committee:

GEN 2, MR 7, 24

interference, boat not racing: MR
18

sportsmanship: MR 13, 24, 25

touching a mark: MR 10

Umpires

cancelling signals: MR 19

sequence of signals: MR 14, 28

Water: UMP 2

wind:

abeam: UMP 14

shifting: UMP 17

windshift: MR 33

windward:

leg: UMP 14, 16, MR 25, 32

mark: UMP 17, 22

wing boat calls: MR 11

Y flags:

answering sequence: MR 14

failure to respond by umpire: MR
15

penalty taken before umpire

signal: MR 17

required for exoneration: MR 10

